

PROGRAMMING THE PC4000

The PC4000 incorporates a new method of programming which uses a menu system to find a specific program location when it is to be entered.

Book 1 contains the programming flow charts for the PC4000. The charts are arranged in such a way as to allow you to quickly find any option and the path required to arrive at the program location. In addition you will be able to see other options also available to you in the program area.

Plain boxes are program areas and shaded boxes are menu selections.

Two methods may be used to select the different menu items to arrive at a program location. With the first, you may use the arrow keys (<>) to scroll through the menu items. When the desired item is displayed press the [★] key. The [★] key is used as an 'ENTER' or 'SELECT' key. The panel will then move you to the next set of options.

The other method incorporates a 'HOTKEY' system. Every menu and program item contains a one or two digit 'HOTKEY' entry. Simply press the number(s) in the menu or program box and the panel will automatically select the item for you. DO NOT PRESS THE [★] AFTER ENTERING THE 'HOTKEY' NUMBER. This second method is much quicker once you become familiar with it.

EXAMPLE: We wish to program the Exit Delay for Partition 4. The following is the flow chart located in Book 1.

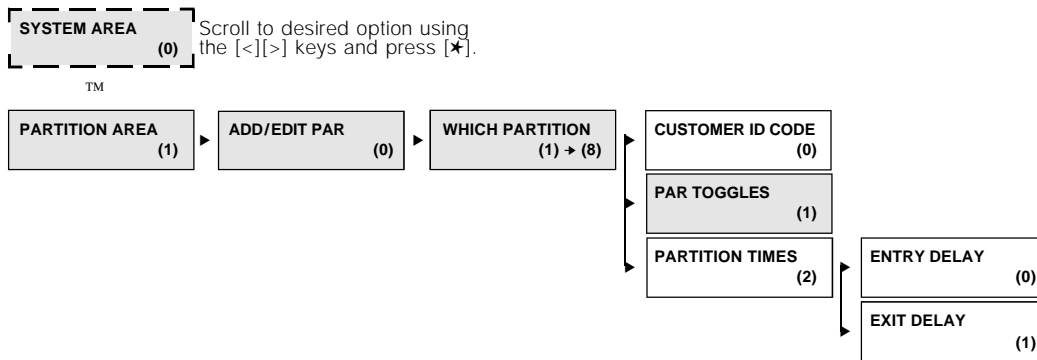

Using the first method the arrow keys would have to be pressed many times to scroll to the various items followed by the [★] key to select the item. Twelve keystrokes would be required after entering Installer Programming providing no mistakes are made. The keystrokes required are as follows:

- [>], [★] to select PARTITION AREA
- [★] to select ADD/EDIT PAR
- [>], [>], [>], [★] to select to PARTITION 4
- [>], [>], [★] to select PARTITION TIMES
- [>], [★] to select EXIT DELAY

Using the second 'HOTKEY' method we require only 5 keystrokes:

- [1] to select PARTITION AREA
- [0] to select ADD/EDIT PAR
- [4] to select PARTITION 4
- [2] to select PARTITION TIMES
- [1] to select EXIT DELAY

With less keystrokes required, programming is quicker as there is less chance of an error occurring.

At any time you may press the [#] key to exit a section. ANY DATA ENTERED WILL BE CHANGED. THE [#] KEY IS NOT AN ABORT KEY! The [#] key can also be pressed to move you back to the previous menu. Pressing the [#] key several times will exit you from Installer Programming.

To make programming easier the INDEX at the back of the Programming Manual includes the chart number beside every option as well as the page number for a description of the option.

PROGRAMMING TOGGLE OPTIONS

Some program areas contain several toggle options which pertain to the menu item selected. Use the arrow keys (<>) to scroll through the various items. Press the [★] key to toggle between [Y]es and [N]o for each feature. Once all the toggle options have been programmed press the [#] key to save you changes return to the previous menu.

PROGRAMMING HEX DIGITS

Often HEX digits are required for a program item. When a HEX digit is required press the [★] key to enter the HEX menu. You may use the arrow keys to scroll through the HEX digits (A through F) and when the desired letter is displayed press the [★] key.

Another much quicker method for entering HEX digits is to, first, press the [★] key followed by the number corresponding to the HEX letter i.e. A = 1, B = 2, C = 3, up to F = 6. The [★] key must be pressed before entering each HEX digit as the software returns you to decimal programming automatically after each entry.

EXAMPLE: To enter data 'ABCD' on a PC4000 you would enter:

[★], [1], [★], [2], [★], [3], [★], [4]

NOTE - The [★] key is required before every HEX digit entered.

PROGRAMMING MANUAL

The PC4000 Installer's Programming is broken down into 5 major sections:

System Area Area for programming options which affect the operation of the entire system. For example communications, downloading, printer options etc. are options which affect the overall system and are programmed in the system area.

Partition Area Area for programming options which pertain to individual partitions. For example the zone assignment, entry delay time and exit delay time are all options which can be programmed for each of the partitions.

Module Hardware For enrolling and deleting modules.

Event Buffer For the installer to reprint the entire event buffer.

Diagnostics For viewing trouble conditions reported by the modules.

		Page
SYSTEM AREA (0)	INSTALLER OPT'S (00)	5
	LCD MESSAGES (01)	6
	CODE ASSIGNMENT (02)	7
	SYSTEM OPTIONS (03)	8
	DLS SECTION (04)	12
	COMMUNICATOR (05)	14
	SW AUX OUTPUT (06)	28
	MAIN BELL OUTPUT (07)	29
	PGM OUTPUTS (08)	30
	RS-232 OPTIONS (09)	34
PARTITION AREA (1)	ADD/EDIT PAR (0)	35
	DELETE PARTITION (1)	42
	COPY PARTITION (2)	42
MODULE HARDWARE (2)	ENROLL MODULE (0)	43
	DELETE MODULE (1)	44
	CONFIRM MODULE (2)	44
EVENT BUFFER (3)	PRN ENTIRE BUFF (0)	45
DIAGNOSTICS (4)	DIAGNOSTICS (0)	46
	BINARY PROGRAM (1)	46
	MEMORIZE VBAT (2)	46
	FACTORY DEFAULT	46

INSTALLER OPTIONS

INSTALLER OPTS (00)

This section contains the Installer's Code, Grand Master Code, 2nd Grand Master Code and Installer's Lockout options.

PGM INST CODE (0)

Program Installer's Code. A new Installer's Code can be programmed. The default setting is 4000. Enter a new 4 digit code using numbers from 0 to 9 only. The installer's code is used to enter [*][8] Installer's Programming Commands. This code should be changed from the default setting before programming is complete to ensure the security of the system.

NOTE: If the installer's code is lost, and installer's lockout is enabled, there is no way to enter installer's programming. The panel will have to return to DSC. Panels returned to DSC with the installer's lockout feature enabled and no other apparent problems will be subject to an additional service charge.

PGM GRAND MASTER (1)

Program Grand Master Code. Master code 001 is the System Grand Master Code. This is the only code which can program other system master codes. The default for this code is '1234'. This code should be changed from the default setting once programming is complete to ensure the security of the system.

PGM 2ND MAS CODE (2)

The Installer may program a second System Grand Master Code which has the same access as the System Grand Master Code 001. The Second Master Code is not one of the programmable 128 access codes in [*][5] programming and therefore cannot be changed by the user. This code may be used as a Master Key for service and trades people. This code is blank by default.

INS LOCKOUT OPTS (3)

Installer's Lockout prevents the installer's code and downloading access code from being returned to their default values when a hardware or software default occurs.

NOTE: Panels returned to DSC with the installer's lockout feature enabled and no other apparent problems will be subject to an additional service charge.

ENABLE LOCKOUT (1)

Selecting this section will enable Installer's lockout and display the message "Ins Lockout Enabled".

DISABLE LOCKOUT (2)

Selecting this section will disable Installer's lockout and display the message "Ins Lockout Disabled".

To avoid accidental lockout, exit Installer's Programming after changing the Installer's Code. Return to Installer's Programming to verify the code has been changed correctly before locking out the panel. This way, if a mistake has been made the option of defaulting the panel is still available.

LCD MESSAGES

LCD MESSAGES (01)

This section will allow you to program unique zone label words in addition to those found in the library and special event messages.

The PC4000 provides a library of 224 factory programmed words for programming zone labels. In addition 32 custom words may be programmed. Any words required that are not in the factory library must be programmed as one of the 32 custom words.

CUSTOM ZONE ID (0)

Programming additional zone labels that are not included in the library of 224 zone labels supplied in Appendix B. See "Zone Label" for assigning the labels to a zone. There are 32 zone labels that can be up to 14 characters in length each. Upon entering this section, use the [<][>] keys to toggle through the 32 programmable zone labels, numbered 224 to 255, and press the [★] key to select which zone label to program. A cursor will appear under the first character of the zone label. The cursor can be moved to left or right using the [<][>] keys. The letters of the alphabet have been divided up among the 1-9 number keys on the keypad.

[1] = A, B, C, 1 [2] = D, E, F, 2 [3] = G, H, I, 3 [4] = J, K, L, 4 [5] = M, N, O, 5
[6] = P, Q, R, 6 [7] = S, T, U, 7 [8] = V, W, X, 8 [9] = Y, Z, 9, 0

For example, if you press the [4] key, the letter 'J' will appear above the cursor on the display. Press the [4] key again, the letter 'K' will appear above the cursor. Press the [4] key a third time and the letter 'L' will appear above the cursor. Press it again and the number '4' will appear on the display. If a different key is pressed, for example the [6] key, the cursor will automatically move to the right one space, and the letter 'P' will be displayed. To erase a character, move the cursor under the character using the [<][>] keys, and press the [0] key.

While programming the zone label, press the [★] key to call up an options menu. To select an option, either press the corresponding number key, or toggle through the options using the [<][>] keys and press the [★] key to select.

[0] Clear Display [1] Clear to End [2] Change Case [3] ASCII Entry (See appendix A)

[0] Clear Display will clear the entire zone label.

[1] Clear to End will clear the display from the character where the cursor was located to the end of the display.

[2] Change Case will toggle the letter entry between upper case letters (ABC...) and lower case letters (abc...).

[3] ASCII Entry is for entering uncommon characters. There are 255 characters, but 000 to 031 are not used. Use the [<][>] keys to toggle through the characters or enter a three digit number from 032 to 255. Press the [★] key to enter the character into the zone label.

EVENT MESSAGES (1)

Event messages are two custom messages programmed by the installer. These messages will be displayed on the keypad when the user fails to arm or an alarm occurs while the system was armed. The maximum length of the messages are 32 characters. See "Custom Zone ID" for letter entry and options menu.

See [★][6][Master Code][6] User Functions in the System Manual for enabling these messages on each partition.

FAIL TO ARM (0)

The "Fail To Arm" message will appear on every keypad on a partition when a valid code is entered but the system is unable to arm because a zone is not secure.

The message will clear after 5 seconds.

This message can be used to remind the user to check all zones and make sure they are secure before attempting to arm the system.

ALARM WHEN ARMED (1)

The "Alarmed When Armed" message appears when a partition is disarmed after an alarm has occurred. The message will be displayed on all keypads on the partition being disarmed. The message will clear after 5 seconds and display the zone(s) that went into alarm.

This message can be used to remind the users of what to do in their situation.

CODE ASSIGNMENT

CODE ASSIGNMENT (02)

Before programming any of the access codes for the user, the installer must first determine and assign the number of access codes each partition will contain. There are 128 access codes available which may be assigned as System Master codes or access codes on any of the 8 partitions.

When the system is first powered up, access code 1 is assigned as a System Master, code [1234]. The remaining 127 codes are assigned as partition 1 codes. In order to assign codes to other partitions they must first be deleted from partition 1.

For example, when partition 1 codes are selected the keypad will display the following message:

PAR 1 CODES
ENT 000-127 127

The keypad is displaying the number of codes assigned to partition 1 (127) as well as the number of codes available for that partition (000 to 127). This means any number of access codes from 0 to 127 can be assigned to partition 1. Enter a number smaller than 127, for example 015. There are now 15 codes assigned to partition 1, and 112 codes available to be assigned to other partitions or as System Masters. If partition 2 codes are selected, the keypad will display 000 codes assigned and 000 to 112 available.

The system default has one System Master Code. This is access code 1 and is referred to as the System Grand Master Code. All installations should have at least one System Grand Master Code as this code is required to program additional System Master Codes.

The Installer's 2nd Grand Master Access code can also be used to program System Master access codes, but it is not one of the assignable 128 access codes. See "Pgm 2nd Master".

It is important to know that once the Code Assignment has been programmed it is not changed later for the following reason:

The panel will assign codes in sequential order. If a system were installed and 10 System Master Codes and 10 Partition 1 Codes were assigned, the panel assigns codes 1 through 10 as System Masters and codes 11 through 20 as Partition 1 Codes.

If later, the number of System Master Codes is increased to 20 the panel will assign codes 1 through 20 as System Master Codes and codes 21 through 30 as Partition 1 Codes. The 10 codes that were assigned as Partition 1 Codes are shifted and now become System Master Codes. Codes 21 through 30 get shifted and now become Partition 1 Codes.

For this reason it is strongly suggested you assign extra codes to each Partition and as System Masters. In the event that extra access codes will be needed room will be available and the problem of codes shifting will be avoided.

In addition, access codes can be programmed to also operate Partition(s) in addition to the one to which it is assigned. For more information regarding this refer to the "[*][5] User Programming Command" section under "Keypad Function".

SYSTEM OPTIONS

SYSTEM OPTIONS
(03)

This section contain options that are relevvant to the entire system. System Toggle options, Keypad Toggle options, Keypad Lockout options and System Time can all be programmed in this section.

Sys Toggle Options

SYS TOGGLE OPT
(0)

Toggle options are in question form. Use the [★] key to toggle between Yes and No to enable or disable the feature. Use the [<][>] keys to scroll through the options.

ZONES EOL
Y

Zones require End of Line Resistors ?

YES= All zones must have a 2200 ohm resistor across them. If the zone is shorted or open, it will be in a violated condition. If the zone is open and programmed as a fire zone, it will be in a trouble condition. See "[★][2] Trouble Display".

No = The zone is normally a closed loop return to ground. The zone will be violated if the loop is open. *NOTE: If any zone is programmed for Fire, they must still use EOL resistors.*

All zones defined as FIRE must have an EOL resistor connected.

CHANGE SYS MAS
Y

Changeable System Grand Master Code

YES= System Grand Master Code can be changed by the end user via Grand Master Code.
NO = The System Grand Master Code can only be changed via installer's programming.

POWER UP SHUNT
Y

Shunt Zones on Power Up?

YES= All zones are considered non-violated by the main control for the first minute that power has been applied to the system. This will allow time for the detectors to "settle" without causing false alarms.

NO = The zones are active upon power up.

AC TBL DISP
Y

AC Trouble Displayed?

YES= The system will monitor the incoming AC power from the transformer.

NO = The system will not monitor the incoming AC power.

60 Hz LINE
Y

Is the incoming AC Frequency 60 Hz?

YES = The incoming AC power from the transformer cycles at 60 Hz. The North American standard is 60 Hz.

NO = The incoming AC power cycles at 50 Hz.

XTAL TIMEBASE
N

YES= The timebase is the internal crystal oscillator.

NO = The timebase is the AC power input.

Timing for the clock in the PC4000 can come from two sources. The 60/50 Hz frequency of the AC power or a crystal oscillator on the circuit board. The default is to use the frequency of the incoming AC because it normally is very stable. However in some locations, the stability of the AC frequency is less reliable. If this is the case then the crystal oscillator should be used.

AC INHIBIT ARM
N

AC inhibits arming?

YES= When an AC trouble condition is present on the main panel, the system cannot be armed, except by auto-arm.

NO = Regardless of the presence of AC, the system can be armed.

DC INHIBIT ARM
N

DC inhibits arming?

YES= When a low battery condition is present on the main panel, the system cannot be armed, except by auto-arm.

NO = Regardless of the presence of a low battery condition, the system can be armed.

ALARMS DISP
N

Alarm displayed?

YES= When the partition is armed, any zones gone into alarm can be viewed by pressing the [<][>] keys.

NO = Show alarms after disarming only.

- | | |
|------------------------------|---|
| BYPASS DISP
N | <p>Bypass displayed?
 YES= When the partition is armed, bypassed zones can be viewed by pressing the [<][>] keys.
 NO = Shows bypassed zones when disarmed only, by pressing [*][1].</p> |
| VIEW PARTNS
Y | <p>View partitions?
 YES= Users are allowed to view the armed/disarmed status of other partitions.
 (See [*][6] User Functions.)
 NO = Users can only view their own partition.</p> |
| AUTOARM SQUAWK
N | <p>YES= The bell output will activate for one second every ten seconds during the auto-arm pre-alert.
 NO = The bell output will not activate during auto-arm pre-alert.</p> |
| BELL SHUT DOWN
Y | <p>YES= The bell output will no longer activate for a zone that has reached the swinger shut down threshold. (See "SWINGER LIMIT." and "SWGR SHUT DOWN".)
 NO = Every time a zone is violated it will reactivate the bell output.</p> |
| FOLLOWS + ALARMS
N | <p>YES= Enables all outputs programmed to follow zones, including PC4216s programmed as "Follow XX-XX", to also annunciate alarms when those zones are armed.
 When the zone is disarmed the output will follow the zone status. When the zone is violated the output will activate. When the zone is restored the output will deactivate.
 When the zone is armed the output indicates alarm status. The output is not activated until the zone is violated and then remains active. When the partition is disarmed the output remains active to indicate which zone caused the alarm. To get the output to follow the zone status the partition must be armed and disarmed.
 NO = Disables the ability to latch alarm status. The output follows zone activity whether armed or disarmed.</p> |

Keypad Toggle Options

KEYPAD TOG OPT (1)	Programming the operation of the 3 keypad emergency keys ([F], [A] and [P]). Toggle options are in the form of questions. Use the [★] key to toggle between Yes and No to enable or disable the feature. User the [<][>] keys to scroll through the options. Regardless of programming each key must be pressed for 2 seconds before the alarm will be activated.
[F] BELL Y	[F] key activates the Bell Outputs? YES= The bell output will activate when the [F] key is pressed. NO = The bell output will not activate when the [F] key is pressed. The bell output for the [F] key is any output (Bell, SW Aux or PGM) that is programmed for Fire and Burg, Inv Fire and Burg, Fire Only and Inv Fire Only.
[F] PULSE BELL Y	[F] key pulses the Bell Output? YES= The bell output, if enabled, will pulse when the [F] key is pressed. NO = The bell output, if enabled, will be steady when the [F] key is pressed. The bell output for the [F] key is any output (Bell, SW Aux or PGM) that is programmed for Fire and Burg, Inv Fire and Burg, Fire Only and Inv Fire Only.
[F] BUZZER Y	The keypad beeps when the [F] key is pressed? YES= The keypad will beep 3 times when the [F] key has been pressed for 2 seconds. NO = The keypad will not sound when the [F] key is pressed.
[A] SIL BELL Y	The bell is silent when the [A] key is pressed? YES= The bell output will not activate when the [A] key is pressed. NO = The bell output will activate when the [A] key is pressed. The bell output for the [A] key is any output (Bell, SW Aux or PGM) that is programmed for Fire and Burg, Inv Fire and Burg, Burg Only and Inv Burg Only.
[A] STDY BELL Y	The bell is steady when the [A] key is pressed? YES= The bell output, if enabled, will be steady when the [A] key is pressed. NO = The bell output, if enabled, will pulse when the [A] key is pressed. The bell output for the [A] key is any output (Bell, SW Aux or PGM) that is programmed for Fire and Burg, Inv Fire and Burg, Burg Only and Inv Burg Only.
[A] AUD BUZZ N	The keypad beeps when the [A] key is pressed? YES= The keypad will beep 3 times when the [A] key has been pressed for 2 seconds. NO = The keypad will not sound when the [A] key is pressed.
[P] SIL BELL Y	[P] key activates the Bell Outputs? YES= The bell output will not activate when the [P] key is pressed. NO = The bell output will activate when the [P] key is pressed. The bell output for the [P] key is any output (Bell, SW Aux or PGM) that is programmed for Fire and Burg, Inv Fire and Burg, Burg Only and Inv Burg Only.
[P] STDY BELL Y	The bell is steady when the [P] key is pressed? YES= The bell output, if enabled, will be steady when the [P] key is pressed. NO = The bell output, if enabled, will pulse when the [P] key is pressed. The bell output for the [P] key is any output (Bell, SW Aux or PGM) that is programmed for Fire and Burg, Inv Fire and Burg, Burg Only and Inv Burg Only.
[P] SILENT BUZ Y	The keypad does not beep when the [P] key is pressed? YES= The keypad will not sound when the [P] key is pressed. NO = The keypad will beep 3 times when the [P] key has been pressed for 2 seconds.

Keypad Lockout Options

KYPD LOCKOUT OPT (2)	Keypad Lockout Options This section contains programming for the keypad lockout feature. After a programmed number of incorrect attempts to enter an access or installer's code the keypad will lockout, preventing the user from performing any function that requires a code to be entered for a programmable amount of time. All other keypad functions not requiring an access code may still be performed. See "KYPD LOCKOUT" under "PAR TOGGLES" to enable the keypad lockout feature on a partition.
TOTAL BAD CODES (0)	Enter the number of incorrect code entries (from 000 to 255) required to activate keypad lockout if the option is enabled. See "PAR TOGGLES", "KYPD LOCKOUT" to enable the keypad lockout feature on a partition.
LOCKOUT DURATION (1)	This section determines the number of minutes the keypad lockout will activate for. Enter the duration of the keypad lockout. Valid entries are from 000 to 255.
LOCKOUT REP CODE (2)	Lockout Reporting Codes. If keypad lockout occurs, a reporting code can be sent to the monitoring station. To enable this feature program a reporting code in this section.

System Times

SYSTEM TIMES (3)	This section will allow you to program the 24 Hour Clock, Date, Zone Loop Response Time and the Bell Cutoff Time.
SYSTEM CLOCK (0)	This section will allow you to program the present time and date into the system. This section should be programmed if you are using Automatic Arming, the On-Site Printer or Test Code Transmission.
SET DATE (0)	Three 2-digit entries are required. The date is entered by month:day:year.
SET 24HR TIME (1)	Two 2-digit entries are required. The time is entered by hour:minute in military time (HH:MM).
ZONE RESPONSE (1)	The zone loop response time is the length of time (002 - 255 x 100 ms) a zone must be violated before it is detected. (100 ms = one tenth of a second.) Minimum zone loop response time is 200 ms. The factory default setting is 005 (500 ms).
<p>The loop response time is in 100 ms increments. The factory default time is 500 ms (005 x 100 ms). The minimum loop response time is 200 ms.</p>	
BELL CUTOFF (2)	Program the amount of time (from 000 to 255 minutes) the bell output will activate when an alarm occurs. The factory default setting is 004 (4 minutes). Bell Cutoff is for any output (Bell, SW Aux or PGM) that is programmed for Fire and Burg, Inv Fire and Burg, Burg Only, Inv Burg Only, Fire Only, and Inv Fire Only.

DOWNLOAD SECTION

DLS SECTION
(04)

This section will allow you to program all options related to downloading.

Download Toggles

DLS TOGGLES
(0)

Downloading Toggle Options. Toggle options are in the form of questions. Use the [★] key to toggle between Yes and No to enable or disable the feature. Use the [<][>] keys to scroll through the options.

RING DETECT
N

YES= The panel will answer after the programmed number of rings.
NO = Ring detect disabled. The only way downloading can occur is by using either the "USER CALL UP" feature or the "PERIODIC CALLUP" feature. Ring detect can be turned on by the end user for 60 minutes if the "USER ENABLE DLS" option is enabled.

USER CALL UP
N

YES= The user can cause the panel to call a remote computer by entering the [★][6][Master Code][7] user callup command. (See also "PHONE NUMBER" and "PANEL ID CODE" in the DLS options.)
NO = The feature is disabled.

DOUBLE CALL
N

YES= If the panel detects 1 or 2 rings on the first call and then is called again within a variable time of 000 to 255 seconds (programmable - see "2 CALL TIMER"), the panel will answer the second call on the first ring. This is useful for bypassing an answering machine on the same line as the panel.
NO = The panel will only answer after the programmed number of rings is reached. See "# OF RINGS".

DLS CALLBACK
N

YES= Callback is enabled. After connection to the panel both the computer and the panel will hang up. The computer will then wait for the panel to call. If there is more than one downloading computer, callback should be disabled.
NO = Callback is disabled. The downloading computer will have immediate access to the control panel once accepted as valid.

PERIODIC DLS
N

YES= Periodic Downloading is enabled. Periodic downloading is used to allow the computer to execute batch files. The computer must be waiting for a call for this feature to be useable. See "Periodic Callup" for programming the time of day and the number of days in between periodic downloads.
NO = Periodic Downloading disabled.

USER ENABS DLS
Y

User Enables Downloading?
YES= The end user may enable ring detect for 60 minutes to allow a computer to access the control panel. If the "RING DETECT" option has been enabled, this option is overridden.
NO = Option disabled.

DLS Options

PERIODIC CALLUP (1)	Programming the time and number of days between periodic downloads. (See "Periodic DLS" for enabling Periodic Downloading.)
SET CYCLE DAYS (0)	Program the number of days (from 000 to 255 days) between periodic downloads.
SET 24HR TIME (1)	Program, in military time, the time of day the panel will call the computer for periodic downloading.
PHONE NUMBER (2)	Enter the telephone number for computer if User Call Up, Periodic DLS, or DLS Callback is enabled. See "PGM TEL NUMBER" for entering a telephone number and options when programming the phone number.
PANEL ID CODE (3)	Panel Identifier Code. This four digit code will allow the computer to identify the panel that is calling. It must be programmed differently for every panel if User Call Up, Periodic DLS or DLS Callback is used.
ACCESS CODE (4)	This four digit code must be programmed the same as the computers. If the code is different the panel will NOT allow any uploading or downloading to take place. It is used to help ensure the security of the system.
2 CALL TIMER (5)	This is the maximum allowable time in seconds between two phone calls when the "Double Call" option has been enabled. Valid entries are between 000 and 255 seconds. (See "Double Call" for enabling the double call feature.)
# OF RINGS (6)	This is the number of consecutive rings the panel must detect before answering the call. (See "Ring Detect" or "User Enabs DLS" for enabling ring detect.) Valid entries are between 001 and 255 rings.

Download Report Codes

DLS REPORT CODES (7)	A reporting code can be sent to the monitoring station when downloading begins and when it completes. "DLS Callback" must be enabled for the lead in reporting code to operate.
LEAD IN REPCODE (0)	Downloading Lead In Reporting Code. This reporting code is sent to the monitoring station after the computer has called the panel and is waiting for the panel to call back. The panel will first call the monitoring station, send this reporting code, and then call the downloading computer. Do NOT program this reporting code if "DLS Callback" is not enabled.
LEAD OUT REPCODE (1)	Downloading Lead Out Reporting Code. This reporting code is sent to monitoring station after the panel has finished downloading with the computer.

COMMUNICATOR SECTION

COMMUNICATOR (05)

All options concerning communications can be programmed, including phone numbers, reporting codes, account numbers and communicator options.

Main Items - Phone #'s/Comm Format/Dialer Direction

MAIN ITEMS (0)

Handling the phone numbers of monitoring stations or remote areas the panel communicates with.

1ST NUMBER (0)

Phone Number 1. The PC4000 can call up to three different phone numbers when reporting any event to a monitoring station. The second and third number can be used as backups if the first or second fail.

2ND NUMBER (1)

2nd Number can report any events programmed if set in the dialer directions and can back up the 1st Number.

3RD NUMBER (2)

3rd Number can report any events programmed if set in the dialer directions. It can also be used to back up the first and/or second phone number.

PGM TEL NUMBER (0)

Enter the communicator telephone number the way you would dial it on a telephone. The total number of digits including dial tone searches and pauses must not exceed 31. Press the [★] key to enter the telephone entry options menu. A "D" for dial tone search is already programmed as the first digit.

[0] Save and Exit [1] Dial tone [2] Pause 2 Seconds [3] Pause 4 Seconds
[4] DTMF [★] [5] DTMF [#]

[0] Save and Exit can be selected for the telephone number to be stored into the panel's memory, or simply press [#] when finished entering the phone number.

[1] Dial tone will add a dial tone search to the telephone number, which will be represented by a 'D' on the display. When the panel does a dial tone search, it looks for dial tone before dialling the programmed telephone number.

[2] Pause 2 Seconds will add a two second pause to the dialing sequence, which will be represented by the letter 'A' on the display.

[3] Pause 4 Seconds will add a four second pause to the dialing sequence, which will be represented by the letter 'E' on the display.

[4] DTMF [★] will input an asterisk, represented by a 'B' on the display. The dialer will output the same frequencies as a touch tone phone would if the '★' key were pressed. (Frequently required to disable call waiting.)

[5] DTMF [#] will add a '#' to the telephone number, represented by the letter 'C' on the display. The dialer will output the same frequencies as a touch tone phone when the '#' key is pressed. (In some instances is used to disable call waiting.)

COMMS FORMAT

(1)

There are 19 formats in the PC4000 for communicating with the monitoring station. The system must be programmed to use the same communications format as the receiver at the monitoring station.

- (00) 10 Bps 1400 - Silent Knight, Ademco Slow
- (01) 20 Bps 2300 - Sescoa, Franklin, DCI, Vertex
- (02) 20 Bps 1400 - Silent Knight Fast
- (03) 40 Bps 2300 - Radionics
- (04) 40 Bps 1400 - Radionics
- (05) 40 Bps 2300 P - Radionics with Parity
- (06) 40 Bps 1400 P - Radionics with Parity
- (07) 10 Bps 1400 X - Silent Knight, Ademco Slow extended
- (08) 20 Bps 2300 X - Sescoa, Franklin, DCI, Vertex extended
- (09) 20 Bps 1400 X - Silent Knight, Ademco Fast extended
- (10) 40 Bps 2300 X - Radionics Extended
- (11) 40 Bps 1400 X - Radionics Extended
- (12) 40 Bps 2300 XP - Radionics Extended with Parity
- (13) 40 Bps 1400 XP - Radionics Extended with Parity
- (14) SIA Fsk Format
- (15) Sescoa Super Speed
- (16) Sescoa Super Speed ID
- (17) DTMF Contact ID
- (18) 4/3 DTMF Format - Surgard

10, 20 and 40 BPS Formats

10 Bits Per Second is the standard slow format used on Silent Knight and Ademco receivers.
Data = 1900 Hz Kisofoff = 1400 Hz Speed = 10 Baud

20 Bits Per Second is the standard fast format used on DCI, Franklin, Sescoa and Vertex receivers.

Data = 1800 Hz Kisofoff = 1400/2300 Hz Speed = 20 Baud

40 Bits Per Second is the standard format used on Radionics receivers.

Data = 1800 Hz Kisofoff = 1400/2300 Hz Speed = 40 Baud

These formats will send an account code to identify which customer is sending the alarm, and a reporting code to identify the type of alarm. Depending on the receiver, the account code must be either 3 or 4 digits, and the reporting code must be either 1 or 2 digits. If the account code needs to be only 3 digits, program the 'System ID Code' and each partition's 'Customer ID Code' with 3 digits, followed by a '0'. If you wish to send a zero in the account code, program it with a HEX A. For example, if you wish to send 103 as your account code, program the System or Customer ID code with '1A30'. If the reporting code needs to only be 1 digit, program the reporting codes with one digit followed by a '0'. For example, to send a '3', program '30' into the reporting codes. To send a zero, program HEX A into the reporting code. For example, to send 30, enter 3A.

Radionics Format

For conventional 3/1 Radionics format the communications mode should be set to either (10) or (11), the 40 Bps extended format. The following guidelines have been provided to help in configuring the PC4000 for Radionics format.

1. The system ID code and customer ID codes must be only 3 digits with a zero making up the 4th digit (i.e. program 1230 for ID code 123.)
2. The zone alarm reporting codes must all be single digit numerical codes with no extended 2nd round being sent. The zero in the 2nd digit of the reporting code tells the PC4000 not to send an extended code.
3. All other non-alarm reporting codes must be set up to send an extended 2nd round. The 1st digit of the reporting code is used to identify the event while the 2nd or extended digit is used to associate the event with a particular item. (i.e. A reporting code of E3 means restore zone 3 - E for restore and 3 for zone 3.)
4. The following is a list of 1st digit identifiers that should be used with the Radionics format.
 - Restorals "E" Example "E3" = Restore zone 3
 - Openings "B" Example "B2" = Opening by User 2
 - Closings "C" Example "C4" = Closing by User 4
 - Troubles "F" Example "F5" = Trouble from Source 5
 - Misc "D" Example "D1" = Partial Closing

SIA 1986 Format

The system ID codes and the customer ID codes must be four decimal digits in length. The reporting codes must be 2 digits.

Do not program the keypad lockout reporting code or the printer buffer nearly full reporting code.

The SIA format will transmit a 4 digit account code, a 2 digit identifier code and a 2 digit reporting code. The 2 digit identifier is preprogrammed by the PC4000. The 2 digit reporting code is programmed by the installer with any hex number from 01 to FE.

Preprogrammed Identifiers

Zone Alarms 1 to 128	- Fire	FA
Zone Alarms 1 to 128	- All others	BA
Zone Troubles 1 to 128		FT
Zone Restorals 1 to 128	- Fire	FR
Zone Restorals 1 to 128	- All others	BR
Module Tamper Alarm		TA
Module Tamper Restoral		TR
Keypad [F] Key Alarm		FA
Keypad [A] Key Alarm		MA
Keypad [P] Key Alarm		PA
Keypad [F] Key Restore		FR
Keypad [A] Key Restore		MR
Keypad [P] Key Restore		PR
Closing Access Codes 1 to 128		CL
Quick Arm Closing Code		CL
Partial Closing Code		CG
Automatic Arming Closing		CA
Opening Access Codes 1 to 128		OP
Opening After Alarm		OR
System Battery Trouble Alarm		YT
System AC Trouble Alarm		AT
System Bell Trouble Alarm		UT
System AUX Supply Trouble Alarm		UT
System Battery Trouble Restoral		YR

Preprogrammed Identifiers

System AC Trouble Restoral	AR
System Bell Trouble Restoral	AR
System Bell Trouble Restoral	UR
System Aux Supply Trouble Restoral	UR
COMBUS Trouble Alarm	UT
COMBUS Trouble Restoral	UR
System TLM REstoral	LR
System FTC REstoral	UR
Downloading Lead In	RB
Downloading Lead Out	RS
Periodic Test	RP
System Test	RX
4204 Battery Trouble Alarm	YT
4204 AC Trouble Alarm	AT
4204 Aux Supply Trouble Alarm	UT
4204 Battery Trouble Restore	YR
4204 AC Trouble Restore	AR
4204 Aux Supply Trouble Restore	UR
2nd Master Close	CL
2nd Master Open	OP

Sescoa Super Speed and SESCOA Super Speed ID

The system ID code and customer ID codes must be four decimal digits in length and in the range of 0001 to 3374.

The reporting codes must be 2 digits in length and programmed as follows. All zero's must be replaced with 'A's. For example, to send 20, the PC4000 must be programmed with a 2A. (To disable a reporting code, leave as FF)

Do not program the Downloading Lead In reporting code, the Downloading Lead Out reporting code, the Installer Lead In reporting code, the Installer Lead Out Reporting Code, the RS-232 Trouble Alarm Rep Code or the RS-232 Trouble Restoral Rep Code.

	<u>Code</u>		<u>Code</u>
Zone Alarms 1 to 128	A1 to 9A	System Aux Supply Trouble Alarm	13
Zone Troubles 1 to 128	91	System Battery Trouble Restoral	E1
Zone Restoral 1 to 128	A1 to 9A	System AC Trouble Restoral	E1
Module Tamper Alarms	92	System Bell Trouble Restoral	F1
Module Tamper Restorals	92	System Aux Supply Trouble Restoral	13
Keypad [F] key Alarm	93	Combust Trouble Alarm	97
Keypad [A] key Alarm	94	Combust Trouble Restore	97
Keypad [P] key Alarm	95	System TLM Restoral	EE
Keypad [F] key Restoral	93	System FTC Restoral	EE
Keypad [A] key Restoral	94	Periodic Test	1C
Keypad [P] key Restoral	95	Buffer Near Full	98
Closing Reporting Codes 1 to 128	CA	System Test	1C
Quick Arm Closing Code	CA	4204 Battery Trouble Alarm	E1
Partial Closing Code	C1	4204 AC Trouble Alarm	E1
Automatic Arming Closing	CA	4204 Aux Supply Trouble Alarm	13
Keypad Lockout Code	96	4204 Battery Trouble Restore	E1
Opening Reporting Code 1 to 128	BA	4204 AC Trouble Restore	E1
Opening After Alarm Code	BA	4204 Aux Supply Trouble Restore	13
System Battery Trouble Alarm	E1	2nd Master Close	CA
System AC Trouble Alarm	E1	2nd Master Open	BA
System Bell Trouble Alarm	F1		

Contact ID

The System ID code and 8 Customer ID codes must be 4 decimal digits. The reporting codes must be 2 digits and programmed as follows. Do not program the Opening After Alarm reporting code, Buffer nearly full reporting code, Installer Lead In and Installer Lead Out Reporting Codes.

Zone Alarms and Restorals can be programmed to send different messages to the monitoring station. For example, if the Reporting code for zone 5 is programmed with '34', the monitoring station will receive the message '★BURG★ - ENTRY/EXIT - 5', where 5 is the number of the zone which has been activated. Different messages to be sent to the monitoring station are:

<u>Code</u>	<u>Message as seen on receiver</u>
Fire Alarms	
1A	★FIRE★ - FIRE ALARM - #
11	★FIRE★ - SMOKE DETECTOR - #
12	★FIRE★ - COMBUSTION - #
13	★FIRE★ - WATER FLOW - #
14	★FIRE★ - HEAT SENSOR - #
15	★FIRE★ - PULL STATION - #
16	★FIRE★ - DUCT STATION - #
17	★FIRE★ - FLAME SENSOR - #

<u>Code</u>	<u>Message as seen on receiver</u>
Panic Alarms	
2A	★PANIC★ - PANIC - #
21	★PANIC★ - DURESS - #
22	★PANIC★ - SILENT PANIC - #
23	★PANIC★ - AUDIBLE PANIC - #

Burglar Alarms

3A	★BURG★ - BURGLARY - #
31	★BURG★ - PERIMETER - #
32	★BURG★ - INTERIOR - #
33	★BURG★ - 24 HOUR - #
34	★BURG★ - ENTRY/EXIT - #
35	★BURG★ - DAY/NIGHT - #
36	★BURG★ - OUTDOOR - #
37	★BURG★ - TAMPER - #

General Alarms

4A	★ALARM★ - GENERAL ALARM - #
44	★ALARM★ - SENSOR TAMPER - #

24 Hour Non-Burglary

5A	★ALARM★ - 24 HR. NON-BURG - #
51	★ALARM★ - GAS DETECTED - #
52	★ALARM★ - REFRIGERATION - #
53	★ALARM★ - HEATING SYSTEM - #
54	★ALARM★ - WATER LEAKAGE - #
55	★ALARM★ - FOIL BREAK - #
56	★ALARM★ - DAY ZONE - #
57	★ALARM★ - LOW GAS LEVEL - #
58	★ALARM★ - HIGH TEMPERATURE - #
59	★ALARM★ - LOW TEMPERATURE - #
61	★ALARM★ - AIR FLOW - #

The rest of the reporting codes must be programmed as follows or left as FF to be disabled.

Zone Troubles	73	System Bell Trouble Restoral	21
Module Tamper Alarm	45	System Aux Supply Trouble RestoralAA	
Module Tamper Restoral	45	Combust Trouble Alarm	3A
Keypad [F] key Alarm	15	Combust Trouble Restore	3A
Keypad [A] key Alarm	AA	TLM Restoral	51
Keypad [P] key Alarm	2A	FTC Restoral	54
Keypad [F] key Restoral	15	Periodic Test Transmission	A2
Keypad [A] key Restoral	AA	System Test	A1
Keypad [P] key Restoral	2A	Downloading Lead In	11
Access Codes 1 to 128 Closing	A1	Downloading Lead Out	12
Quick Arm Closing	A8	4204 Battery Trouble Alarm	3A
Partial Closing	74	4204 AC Trouble Alarm	3A
Auto Arm Closing	A3	4204 Aux Supply Trouble Alarm	3A
Keypad Lockout	21	4204 Battery Trouble Restoral	3A
Access Codes 1 to 128 Opening	A1	4204 AC Trouble Restoral	3A
System Battery Trouble Alarm	A2	4204 Aux Supply Trouble Restoral	3A
System AC Trouble Alarm	A1	RS-232 Trouble Alarm	35
System Bell Trouble Alarm	21	RS-232 Trouble Restoral	35
System Aux Supply Trouble Alarm	AA	2nd Master Close	A1
System Battery Trouble Restoral	A2	2nd Master Open	A1
System AC Trouble Restoral	A1		

Surgard 4/3 DTMF Format

This is a 7 digit format sent by DTMF tones and uses a 2300 Hz handshake. Each round pair represents a single event as follows:

SSSSXCC

where, SSSS= 4 digit account code

x = Event descriptor, preprogrammed in the PC4000.

CC = 2 digit reporting code programmed by the installer.

The reporting codes can be programmed with any hex number from 01 to FE (00 or FF will disable the reporting code).

Note that both "0" and "A" will both represent and be received as "0".

Normally the Zone Alarm reporting codes will transmit a "3" as the event descriptor for most zone types, to indicate a burglary alarm. However, if the zone type is a Standard Fire Zone, Delayed Fire Zone or Auto Verify Fire Zone, the PC4000 will transmit a "1" as the event descriptor for these zone types to indicate a fire alarm is being transmitted.

For zones programmed as momentary keyswitch arming or maintained keyswitch arming, the PC4000 will transmit a "4" and the reporting code programmed in the "Zone Alarm" section to indicate a closing (arming) of a partition.

In the Zone Restore reporting codes section, a zone will normally transmit a "9" as the event descriptor for burglary or fire zones to indicate the zone has been restored. However, if the zone has been programmed as a momentary or maintained keyswitch arming zone, when the zone is used to disarm a partition it will transmit a "5" and the reporting code programmed in the zone restoral section to indicate an opening (disarming) of a partition.

<u>PC4000 Reporting Code Section</u>	<u>Event Descriptor</u>
Zone Alarms 1 to 128 (Fire Alarms)	1
Zone Alarms 1 to 128 (Keyswitch Arming)	4
Zone Alarms 1 to 128 (All others)	3
Zone Troubles 1 to 128	6
Zone Restorals 1 to 128 (Keyswitch Disarming)	5
Zone Restorals 1 to 128 (All others)	9
Module Tamper Alarm	F
Module Tamper Restoral	9
Keypad [F] key Alarm	1
Keypad [A] key Alarm	7
Keypad [P] key Alarm	2
Keypad [F] key Restore	9
Keypad [A] key Restore	9
Keypad [P] key Restore	9
Closing Access Codes 1 to 128	4
Quick Arm Closing Code	4
Partial Closing Code	D
Automatic Arming Closing	4
Keypad Lockout Code	F
Opening Access Codes 1 to 128	5
Opening After Alarm	F
System Battery Trouble Alarm	6
System AC Trouble Alarm	6
System Bell Trouble Alarm	6
System Aux Supply Trouble Alarm	6
System Battery Trouble Restoral	9
System AC Trouble Restoral	9
System Bell Trouble Restoral	9
System Aux Supply Trouble Restoral	9
COMBUS Trouble Alarm	6
COMBUS Trouble Restoral	9
System TLM Restoral	9
System FTC Restoral	9
Downloading Lead In	F
Downloading Lead Out	F
Periodic Test	0
Buffer Near Full	F
System Test	0
4204 Battery Trouble Alarm	6
4204 AC Trouble Alarm	6
4204 Aux Supply Trouble Alarm	6
4204 Battery Trouble Restore	9
4204 AC Trouble Restore	9
4204 Aux Supply Trouble Restore	9
2nd Master Close	4
2nd Master Open	5

DIALER DIRECTION
(2)

This section determines which reporting codes are sent to the selected phone number. All reporting codes can be programmed to communicate to any or all of the phone numbers. By default, all reporting codes are sent to phone number 1 only. See "Comms Toggles" for using phone numbers 2 and 3 as backup phone numbers.

ALARM/RESTORE
Y

YES = Alarm and Restoral reporting codes are transmitted to the monitoring station by the selected phone number.

NO = Alarm and Restoral reporting codes are not sent.

The groups of reporting codes, those are Alarms and Restorals, are:

- Zone Alarms ▪ Zone Restorals ▪ Module Tamper Restorals
- Zone Troubles ▪ Module Tamper Alarms ▪ [F][A][P] keys

See "Reporting Codes" for a description of these groups of reporting codes.

All alarms and restorals will be sent to all phone numbers with this option toggled to "YES". If another phone number is to be used as a back up then "NO" should be selected, as the panel will automatically call in the event of a failure on the first number. If "YES" is selected for the back up number as well then the panel will always call both numbers.

OPEN/CLOSE
Y

YES = Opening and Closing reporting codes are transmitted to the monitoring station by the selected phone number.

NO = Opening and Closing reporting codes are not sent.

The groups of reporting codes, those are Openings and Closings, are:

- Closings by Access Codes 001 to 128 ▪ Openings by Access Codes 001 to 128
- Misc Closing Reporting Codes ▪ Misc Opening Reporting Codes
- 2nd Master Close ▪ 2nd Master Open

See "Reporting Codes" for a description of these groups of reporting codes.

All openings and closings will be sent to all phone numbers with this option toggled to "YES". If another phone number is to be used as a back up then "NO" should be selected, as the panel will automatically call in the event of a failure on the first number. If "YES" is selected for the back up number as well then the panel will always call both numbers.

ALL OTHERS
Y

YES = All other reporting codes are sent to the selected phone number

NO = All other codes are not sent.

"All other" refer to every other reporting code that is not an alarm or restoral, opening or closing.

"All other" groups of reporting codes are:

- System Maintenance Reporting Codes ▪ 4400 Module Maintenance Reporting Codes
- 4204 Module Maintenance Reporting codes

See "Reporting Codes" for a description of these groups of reporting codes.

All other reporting codes will be sent to all phone numbers with this option toggled to "YES". If another phone number is to be used as a back up then "NO" should be selected, as the panel will automatically call in the event of a failure on the first number. If "YES" is selected for the back up number as well then the panel will always call both numbers.

SYSTEM ID CODE
(3)

When a reporting code is sent to the monitoring station, a four digit account code is also sent to identify the user. Each partition has its own account code (See "Customer ID Code"). But for reporting codes that do not pertain to a particular partition, such as AC line trouble etc., the system ID code is sent to identify the panel/user. The reporting code groups that send the system ID code are:

- Module Tamper Alarms ▪ System Maintenance Reporting Codes
- Module Tamper Restorals ▪ 4204 Module Maintenance Reporting Codes
- 4400 Module Maintenance Reporting Codes

See "Reporting Codes" for a description of these groups of reporting codes.

See "Comms Formats" for a description of communication formats and if there are limitations set on what the System and Partition account codes may be programmed as.

The system ID code must be programmed as it is the account number which the panel will use to report all events that do not pertain to a partition such as trouble signals. If the panel is to report all events with the same account number, the system ID code should be the same as the account number for the partition(s).

Communicator Toggles

COMMS TOGGLES (1)	Selecting options relevant to the communications of the panel. Toggle options given in the form of a question. Use the [★] key to toggle between [Y]es and [N]o to enable or disable the feature. Use the [<][>] keys to scroll through the options.
COMMS ENABLED Y	<p>Communications are enabled?</p> <p>YES= The communications are enabled.</p> <p>NO = The communications are disabled. No reporting codes will be transmitted to the monitoring station. Note that downloading can still be accomplished with the communicator disabled.</p>
DTMF DIALING Y	<p>YES= The dialer will use DTMF dialing. The PC4000 can switch to pulse dialing after a programmed number of attempts at DTMF dialing have failed. See "DTMF Attempts".</p> <p>NO = The dialer will use pulse dialing.</p>
RESTORE ON BTO Y	<p>Restore on Bell Time Out?</p> <p>YES= The panel will send the restoral reporting code when both the zone is restored and the bell has timed out (see "BELL CUTOFF" for the time the bell will time out). Note that if the zone is not restored, the restoral will be sent when the partition is disarmed. DO NOT enable this feature if "REST ON DISARM" is enabled.</p> <p>NO = The panel will send the restoral reporting code when the zone is restored, or if "REST ON DISARM" is enabled, the restoral is sent when the partition is disarmed. (See "REST ON DISARM".)</p>
REST ON DISARM N	<p>Restore on Disarming?</p> <p>YES= The panel will send a restoral when the partition has been disarmed. The panel will not send another alarm transmission for the zone until the partition is disarmed. DO NOT enable "RESTORE ON BTO" if this feature is enabled. (See "RESTORE ON BTO".)</p> <p>NO = The panel will send the restoral immediately when the zone is restored, or if "RESTORE ON BTO" is enabled, the restoral is sent when the bell times out. (See "RESTORE ON BTO".)</p>
SHUT DOWN 24HRS N	<p>Swinger Shutdown reset every 24 hours?</p> <p>YES= The swinger shutdown counters will be reset everyday at midnight. The swinger shutdown counters keep track of how many alarms have occurred on each zone before entering shutdown, in which the zones will no longer cause an alarm. See "SWINGER LIMIT" and "SWGR SHUT DOWN" to enable swinger shutdown.</p> <p>NO = The swinger shutdown counters will be reset when the partition is armed.</p>
PC ID N	<p>Partial Closings Identified?</p> <p>YES= The panel will identify all manually bypassed zones when the partition is armed. The bypassed zones are identified by sending the zone alarm reporting codes for the bypassed zones between the partial closing reporting code and the closing code. The partial closing reporting code must be programmed for this feature to work. See "MISC CLOSING" to program the partial closing reporting code. See "PC ID RESTORES" to use zone restoral reporting codes instead of zone alarm reporting codes to identify the bypassed zones.</p> <p>NO = The panel will only send a partial closing reporting code to tell the monitoring station that zones were bypassed when the partition was armed.</p>

<p>PC ON AUTO ARM Y</p>	<p>Partial Closings on Auto Arming? YES= The panel will send the partial closing reporting code to the monitoring station when a zone is force armed (temporarily bypassed) by an auto arm. If the option "PC ID" is enabled, the force armed zone will be identified by sending its zone alarm reporting code after the partial closing reporting code. See "FORCE ARM" for an explanation of force arming. NO = No partial closing reporting code will be sent when zones are force armed during auto arming.</p>
<p>PC ID RESTORES N</p>	<p>Partial Closings Identified send Zone Restorals? YES= The zone restoral reporting codes are transmitted to the monitoring station instead of the zone alarm reporting codes to identify the manually bypassed zones and force armed zones on auto arm. See "PC ID". NO = The zone alarm reporting codes are used to identify the bypassed zones.</p>
<p>TLM ENABLED Y</p>	<p>Telephone Line Monitoring Enabled? YES= The system tests for telephone line faults. If a fault is detected, the trouble is annunciated on the keypads. A telephone line trouble is generated when the line voltage drops below 3 volts for more than 30 seconds. NO = Does not test for Telephone Line faults.</p>
<p>TLM AUD BELL Y</p>	<p>Telephone Line Monitoring has Audible Bell Alarm? YES= If there is a Telephone Line trouble and a partition is armed, the bell outputs for the armed partition will be activated, along with the keypad annunciation. The bell outputs are any outputs (Bell, SW Aux or PGM) programmed for "FIRE AND BURG", "INV FIRE/ BURG", "BURG ONLY" and "INV BURG ONLY". NO = If there is a Telephone Line trouble, the panel will annunciate the trouble at the keypad only.</p>
<p>FTC AUD BELL N</p>	<p>Should a Failure to Communicate sound the Bells? YES= If a partition is armed, the bell outputs for the armed partition will sound when the PC4000 fails to communicate with the monitoring station. NO = A failure to communicate will not cause the PC4000 to sound the bells.</p>
<p>TLM + ALARM AUD N</p>	<p>Should a Transmission Line Monitoring trouble and an alarm occurring cause the bells to sound? YES= If a partition is armed, the bell outputs for the armed partition will sound when the PC4000 has both a TLM fault and an alarm occurring. NO = The TLM and Alarm Audible Function is disabled.</p>
<p>RINGBACK N</p>	<p>Enable Ringback? YES= The Ringback option is enabled. A successful communication to the monitoring station will be annunciated by the keypads beeping 5 times. If the communications are for reporting an alarm for a partition, only the keypads belonging to that partition will beep. If the reporting code was for a system alarm, all of the keypads will beep. Note that if communications are being sent to more than one telephone number, communications to both numbers must be completed before the ringback will occur. NO = The Ringback option is disabled.</p>
<p>PERIODIC TX ? N</p>	<p>Periodic Test Transmission? YES= The panel will send a test transmission to the monitoring station. See "TEST CODE TX" for programming time and frequency the code is sent. See "SYSTEM MAINT" for programming the reporting code. NO = The panel will not send a test transmission.</p>

<p>EUROPE DIAL N</p>	<p>European Dialling? YES= When the communicator is pulse dialling, the contact closure to the phone line is made in a 67/33 make/break ratio. This is the European standard method of dialling. NO = The contact closure to the phone line is made in a 60/40 make/break ratio. This is the American/Canadian standard method of dialling.</p>
<p>DEFAULT DIAL Y</p>	<p>Dial if No Dial Tone Present? YES= If the first attempt by the panel to call the monitoring station fails, on every subsequent attempt the panel will dial regardless of the presence of dial tone. NO = If a 'D' for dial tone search precedes the phone number, the panel will not dial if dial tone is not present. See "PGM TEL NUMBER" for programming the telephone numbers with dial tone search.</p>
<p>PH 1-2 BACKUP N</p>	<p>Phone #2 back up Phone #1? YES= The PC4000 will send the reporting code to the 2nd phone number if the 1st phone number fails to communicate with the monitoring station after 10 attempts. Dialer directions for the 2nd phone number should be disabled (set to "N") if the 2nd number is used for backup only, otherwise the reporting codes will be sent to the 2nd phone number whether the 1st number failed or not. NO = Disabled. The 2nd phone number does NOT back up the 1st phone number.</p>
<p>PH 1-3 BACKUP N</p>	<p>Phone #3 back up Phone #1? YES= The PC4000 will send the reporting code to the 3rd phone number if the 1st phone number fails to communicate with the monitoring station after 10 attempts. Dialer directions for the 3rd phone number should be disabled (set to "N") if the 3rd number is used for backup only, otherwise the reporting codes will be sent to the 3rd phone number whether the 1st number failed or not. If "PH 1-2 BACKUP" is enabled when 1st phone number fails, the reporting code will be sent to both the 2nd and 3rd phone number. NO = Disabled. The 3rd phone number does NOT back up the 1st phone number.</p>
<p>PH 2-3 BACKUP N</p>	<p>Phone #3 back up Phone #2? YES= The PC4000 will send the reporting code to the 3rd phone number if the 2nd phone number fails to communicate with the monitoring station after 10 attempts. Dialer directions for the 3rd phone number should be disabled (set to "N") if the 3rd number is used for backup only, otherwise the reporting codes will be sent to the 3rd phone number whether the 2nd number failed or not. If "PH 1-2 BACKUP" is enabled when 1st phone number fails, the reporting code will be sent to the 2nd phone number. If the 2nd phone number fails, the reporting code will then be sent to the 3rd phone number. NO = Disabled. The 3rd phone number does NOT back up the 2nd phone number.</p>

Communicator Miscellaneous

<p>COMMS MISC (2)</p>	<p>Program other options relating to the communications of the panel including DTMF attempts, swinger shutdown level, AC failure and zone transmission delay.</p>
<p>DTMF ATTEMPTS (0)</p>	<p>The number of attempts using DTMF dialing (e.g. a touch tone phone) before switching to pulse dialing (e.g. a rotary phone). Enter a three digit number from 000 to 010 attempts. Note that the PC4000 will only call a number 10 times before a Failure to Communicate trouble occurs. By default, the panel will have 2 attempts of DTMF dialing before pulse dialing. If "DTMF DIALING" is not enabled, the panel will only pulse dial.</p>
<p>SWINGER LIMIT (1)</p>	<p>Enter the number of alarm/restore pairs the panel will communicate per zone before communications for that zone shut down. The bell will also shut down if so programmed (see "BELL SHUTDOWN"). Valid entries are from 000 to 255. Entering 000 in this section will disable swinger shutdown. See "SWGR SHUT DOWN" to enable swinger shut down on each zone.</p>
<p>AC FAIL TX DELAY (2)</p>	<p>Enter the time in minutes, AC trouble on the main panel must be present before the AC trouble reporting code will be communicated. Valid entries are from 000 to 255. This delay does not include PC4204 AC troubles, which are communicated immediately.</p>
<p>ZONE TX DELAY (3)</p>	<p>Enter the time in seconds, the panel will delay communication of an alarm zone. Valid entries are from 000 to 255. If the panel is disarmed within the programmed time, no alarm communication will be sent. See "TX DELAY?" under zone toggle options to enable the transmission delay on each zone.</p>

Test Code Transmission

TEST CODE TX (4)	Test Code Transmission. Programs items regarding the test transmission of the panel. To send a test transmission, the time of day, the number of days between test transmissions and the test transmission reporting codes must be programmed. Also the "PERIODIC TX?" comms toggle options must be enabled.
SET CYCLE DAYS (0)	Enter the number of days between test code communications. Valid entries are from 001 to 255.
SET 24HR TIME (1)	Enter the time of day the test code will be communicated. Times are entered using military format HH:MM.
REPORTING CODE (2)	Enter the test transmission reporting code. This is the same reporting code as the "Periodic Test" reporting code programmed in the "System Maint" section.

Reporting Codes

REPORTING CODES (3)	Reporting codes are 2 digit codes which are sent to the receiver at the monitoring station along with the customer ID code for each transmission. They identify the type of alarm to the receiver (See "Comms Format"). Once you have selected which group of reporting codes to program, use the arrow keys to toggle through the reporting codes, and enter in a 2 digit number. If you are sending a 3/1 or 4/1 format where the reporting code needs to only be one digit, program the one digit followed by a "0". For example, if you want to send a "5" to the monitoring station, program "50" into the reporting code. To disable a reporting code, program it with FF (default setting). Pressing the [★] key when entering the code will call up a menu for hex digit entry and to "Save and Exit" from the Reporting Codes menu. <i>NOTE: When programming Hex digits, the second ★ is no longer used as in previous panel versions. (i.e. PC3000 and PC2550). E.g. in the PC4000★ 1★ 2 is AB ★ 1 2 is A2</i>
ZONE ALARM (00)	Alarm Reporting Codes for Zones 001 to 128.
ZONE TROUBLE (01)	Zone Trouble Reporting Codes for zones 001 to 128. The only types of zones that will cause a zone trouble are the standard fire zones, the delayed fire zones and the auto verifying fire zones.
ZONE RESTORE (02)	Restoral Reporting Codes for Zones 001 to 128. See Restore on BTO and Rest on Disarm for when the zone restoral will be sent to the monitoring station.
MOD TAMP ALARM (03)	Reporting Codes for Tamper Alarms on Modules. All modules have a tamper zone, if the tamper is activated.
LCD4500 KEYPADS (0)	There are 16 keypad tamper alarm reporting codes, one for each keypad that can be enrolled onto the system.
PC4400 RS-232 (1)	There is 1 RS-232 tamper alarm reporting code.
PC41XX ZONE EXP (2)	There are 16 reporting codes for tamper alarms on 4108 and 4116 zone expansion modules. If you use all 4108's, the maximum number of expansion modules you will use is 14. (14 x 8 zones = 112 zones + 16 zones on the main panel = 128 zones) For this reason, 15 and 16 are for future use.
PC4216 16 O/P (3)	There are 9 module tamper alarm reporting codes, one for each 4216 module that can be enrolled onto the system.

PC4204 4 O/P (4)	There are 16 module tamper alarm reporting codes, one for each 4204 that can be enrolled onto the system.
MOD TAMP RESTORE (04)	Reporting Codes for the restoral of a modules tamper.
LCD4500 KEYPADS (0)	There are 16 keypad tamper restoral reporting codes, one for each keypad that can be enrolled onto the system.
PC4400 RS-232 (1)	There is 1 RS-232 tamper restoral reporting code.
PC41XX ZONE EXP (2)	There are 16 reporting codes for tamper restorals on 4108 and 4116 zone expansion modules. If you use all 4108's, the maximum number of expansion modules you will use is 14 (14 x 8 zones = 112 zones + 16 zones on the main panel = 128 zones). For this reason, reporting codes 15 and 16 are for future use.
PC4216 16 O/P (3)	There are 9 tamper restoral reporting codes, one for each 4216 module that can be enrolled onto the system.
PC4204 4 O/P (4)	There are 16 module tamper restoral reporting codes, one for each 4204 that can be enrolled onto the system.
[F][A][P] KEYS (05)	[F] [A] [P] KEYS Reporting Codes for [F]ire, [A]uxiliary, [P]anic key alarms and [F]ire, [A]uxiliary, [P]anic key restoral codes.
CLOSINGS (06)	Reporting Codes for Closings by Access Codes. There are 128 reporting codes, one for each access code.
MISC CLOSINGS (07)	Miscellaneous Reporting Codes for Closings. These 4 reporting codes are for Quick Arm, Partial Closing, Auto Arm Closing, and Keypad Lockout. <ul style="list-style-type: none"> ■ Quick Arm - See [★][0] user function in the system manual. ■ Partial Closing - If a partition auto-arms, and some zones were open, the system will force arm itself, bypass the open zones and send the partial closing reporting code to the monitoring station along with the alarm reporting codes of the zones that are open. Also, if zones were manually bypassed, the partial closing reporting code will be transmitted. ■ Auto Arm Closing - When the system Auto-arms, the panel will send the auto-arm reporting code to the monitoring station. See Auto-arm [★][6] functions in the System Manual. ■ Keypad Lockout - If too many incorrect access codes (see "TOTAL BAD CODES" under Keypad Lockout Options for programming the number of incorrect code entries) are entered, the keypad will lock up, preventing anyone from attempting to enter any more access codes. When keypad lockout occurs, the keypad lockout reporting code is sent to the monitoring station.
OPENINGS (08)	Reporting Codes for openings by Access Codes. There are 128 reporting codes, one for each access code.
MISC OPENINGS (09)	Miscellaneous Reporting Code for Openings. The one for miscellaneous openings is the Opening After Alarms Reporting Code. An opening after alarm reporting code is sent to the monitoring station when the system is disarmed, and there was an alarm while the system was armed.

SYSTEM MAINT

(10)

System Maintenance Reporting Codes. There are 19 reporting codes dealing with the operation and maintenance of the system. The reporting codes are:

- Battery Trouble and Battery Restoral - If the battery voltage on the PC4000 main panel is weak, disconnected or if the battery fuse fails, a battery trouble occurs, and the battery trouble reporting code is sent. When the battery voltage and fuse are restored, the battery restoral code is sent. See Battery Trouble under Trouble Display [★][2] in the System Manual.
- AC Line Trouble and AC Line Restoral - If the incoming AC voltage to the AC terminals fails, an AC trouble occurs and the AC trouble reporting code is sent to the monitoring station after the AC Fail Tx Delay has elapsed (see "AC FAIL TX DELAY"). When the incoming AC is restored, the AC restoral reporting code is sent to the monitoring station. See AC Trouble under Trouble Display [★][2] in the System Manual.
- Main Bell Trouble and Main Bell Restoral - If a bell trouble occurs, either from the bell fuse failure or the open bell terminals, the Main Bell Trouble reporting code will be sent to the monitoring station. When the trouble condition is restored, the Main Bell Restoral reporting code will be transmitted.
- Main Aux Trouble and Main Aux Restoral - If an auxiliary voltage supply trouble occurs, the Main Aux Trouble reporting code is transmitted, and when the auxiliary voltage supply is restored, the Main Aux Restoral code is transmitted.
- COMBUS Trouble and COMBUS Restoral - When the main panel loses communication with a module, the Combus Trouble reporting code will be transmitted, and when communications resume the Combus Restoral reporting code will be sent.
- TLM Restoral - If there is a telephone line monitoring trouble, the PC4000 will not be able to communicate with the monitoring station until the telephone line is restored, then the TLM Restoral reporting code will be sent.
- FTC Restoral - If a failure to communicate trouble occurs, where the PC4000 could not get through to the monitoring station, the next time the panel attempts to communicate and is successful, it will also transmit the FTC restoral reporting code.
- Periodic Test - This is the reporting code that is sent to the monitoring station to test communications. This is the same reporting code that can be programmed in the 'Test Code Tx' section, where the cycle time for the test transmission is programmed.
- Buf Near Full - This reporting code is sent to the monitoring station when the Event Buffer on the PC4000 is 75% full. The event buffer holds up to 512 events, therefore when the event buffer has 384 events recorded, the Buffer Near Full reporting code will be transmitted.
- User System Test - When the user does a [★][6] bell/comm test, the User System Test reporting code is sent to the monitoring station to test communications. See "BELL/COMM TEST" in the System Manual.
- DLS Lead In and DLS Lead Out - If the DLS Lead In reporting code is to be used, the DLS callback feature must be enabled. (See DLS callback under DLS Toggles). When a computer calls the PC4000 panel, after connection is made, both the panel and the computer will hang up the telephone line. The panel will then transmit the DLS Lead In reporting code to the monitoring station. The panel will then call the computer and begin downloading. When the computer is finished downloading to the panel, they will both hang up the phone line, and the PC4000 will transmit the DLS Lead Out reporting code to the monitoring station.
- Ins Lead In and Ins Lead Out - The Installer's Lead In reporting code is sent to the monitoring station when an installer enters the [★][8] installer's programming mode. The Lead Out code is sent when the installer leaves [★][8] installer's programming.

4204 MOD MAINT

(11)

The PC4204 module maintenance reporting code section has reporting codes for sixteen modules, with 6 codes for each module, in a total of 96 reporting codes. The 6 codes for each module are Battery Trouble, AC Line Trouble, Aux Supply Trouble, Battery Restoral, AC Line Restoral and Aux Supply Restoral. These reporting codes are similar to the system maintenance reporting codes for the PC4000 main panel.

4400 MOD MAINT

(12)

The PC4400 module maintenance reporting code section has 2 reporting codes, RS-232 Trouble and RS-232 Restoral. If there is a problem that the RS-232 cannot transmit, the RS-232 Trouble reporting code is sent to the monitoring station. When the problem is cleared, and the RS-232 has successfully transmitted, the RS-232 restoral is sent to the monitoring station.

2ND MASTER CLOSE

(13)

The Second System Grand Master Code used by the installer has a reporting code to report when it has been used to arm a partition.

2ND MASTER OPEN

(14)

The Second System Grand Master Code used by the installer has a reporting code to report when it has been used to disarm a partition.

SWITCHED AUXILIARY OUTPUT

**SW AUX OUTPUT
(06)**

The switched auxiliary output terminal on the main panel is a 12 volt power supply activated and deactivated by any one of 23 options. When the switched auxiliary is activated, it outputs 12 volts (if measured, will read 13.8 volts). The switched auxiliary output, for some options can also be programmed to activate for only selected partitions.

For example:

If the SW AUX output has been programmed for Sensor Reset and enabled on partition 1 and partition 2.

Pressing [★][4] on any keypad assigned to partition 1 or partition 2 will deactivate the output for the amount time programmed in "PGM PULSE TIME".

Pressing [★][4] on a keypad assigned to partitions 3 to 8 will not activate the output.

Refer to the PGM OUTPUTS LIST for the list of options available.

MAIN BELL OUTPUT

**MAIN BELL OUTPUT
(07)**

The bell output on the main control board can be programmed to activate for any one of the 23 PGM output options on any number of partitions. The BELL terminal is normally 13.8 VDC and will switch to ground potential when activated. The BELL terminal will be at ground potential and switch to 13.8 VDC if any "INV" option is selected. If the bell output is not being used, a 2200 ohm resistor must be connected across the terminals as the output is supervised.

PGM OUTPUTS

Main PGM Output

MAIN PGM OUT
(0)

The PGM output can be programmed to activate for any one of the 23 options listed in the PGM outputs list. Normally the output will be open collector (not active) and will switch to ground potential (active). The output will switch from ground potential (active) to open collector (not active) if any "INV" options is selected.

PC4204 Options

4204 OPTIONS
(1)

Relay 1 of all PC4204 modules must be left as default, COMBUS Power, option 19. Relay 2, 3 and 4 of any PC4204 module can be programmed to activate for any of the 23 options listed in the PGM Outputs list. Normally each relay will energize when active. If any 'INV' option is selected the relay will normally be energized and then de-energized when active.

PC4216 Options

4216 OPTIONS
(2)

Each PC4216 module connected to the system can be programmed to operate as an alarm annunciator, zone follower or both. In addition one PC4216 module can be custom programmed, each of the 16 outputs programmable to activate for any of the 23 options listed in the PGM Output list.

CUSTOM PGM ARRAY
(00)

The custom PGM array allows each of the 16 outputs to be individually programmed with one of the 23 options listed in the PGM outputs list. Each outputs are programmed in the "4216 CUSTOM" section. More than one PC4216 can be programmed as a Custom PGM Array, but all of them will be following the same options. For example, in the "4216 CUSTOM" section. If output 1 is programmed as "TLM ONLY", and there are two PC4216's programmed as Custom PGM Array. When a TLM trouble occurs, output 1 on both modules will activate.

ALARMS 1-16
(01)

The 8 selections of "ALARMS XX-XX" are for programming the PC4216 to annunciate alarms. The 16 outputs will activate for each of the corresponding selected zones. The output will remain active, even when the partition is disarmed, for continuously showing the zones which have gone into alarm. The outputs will deactivate the next time the partition is armed. For example, a PC4216 is programmed for Alarms 49-64. If zone 53 goes into alarm, the output will activate and remain active even when the bells are silenced and the partition is disarmed. The outputs will reset when the partition is armed again. More than one PC4216 can be programmed to annunciate the same zones.

FOLLOW 1-16
(09)

The 8 selections of "FOLLOW XX-XX" are for programming the PC4216 to annunciate open zones. The 16 outputs will activate for each of the corresponding selected zones. The output will activate when the zone is open, and deactivate when the zone is restored. More than one PC4216 can be used to annunciate the same group of 16 zones. For example, PC4216 #1 is programmed as Follow 33-48 and #5 is programmed as Follow 33-48. If zone 34 is opened, output 2 on both 4216's will activate. See "Follows + Alarms" for making outputs act as a zone follower and alarm annunciator.

4216 CUSTOM
(3)

This section is for programming the 16 outputs on a PC4216 as Custom PGM Array, with different options listed in the "PGM OUTPUTS LIST". More than one PC4216 can be programmed as Custom PGM Array, which will follow the same 16 output options.

PGM Pulse Times

PGM PULSE TIMES
(4)

This section will allow you to select the time the PGM output will remain active after being triggered.

UTILITY/SENSOR
(0)

The main bell, switched auxiliary or any of the PGM outputs programmed for "Utility Output" or "Sensor Reset", can be active for 000 to 255 seconds.

KISSOFF PULSE
(1)

Any output programmed for "Kissoff Output" can be active for 000 to 255 seconds.

GROUND START
(2)

Any output programmed for "Ground Start" can be active for 000 to 255 seconds.

CHIME PULSE
(3)

Any output programmed for "Chime Pulse" can be active for 000 to 255 seconds.

PGM OUTPUTS LIST

FIRE AND BURG
(00)

The output will activate when any fire or zone alarm occurs on any of the selected partitions.

INV FIRE/BURG
(01)

The output will deactivate when any fire or zone alarm occurs on any of the selected partitions.
NOTE: This option must only be enabled on enabled partitions.

BURG ONLY
(02)

The output will activate when any zone alarm occurs on any of the selected partitions.

INV BURG ONLY
(03)

The output will deactivate when any zone alarm occurs on any of the selected partitions.
NOTE: This option must only be enabled on enabled partitions.

FIRE ONLY
(04)

The output will activate when any fire alarm occurs on any of the selected partitions.

INV FIRE ONLY
(05)

The output will deactivate when any fire alarm occurs on any of the selected partitions.
NOTE: This option must only be enabled on enabled partitions.

UTILITY OUTPUT
(06)

The output will activate when [*][7] is entered on any keypad on any of the selected partitions.

SENSOR RESET
(07)

The output will deactivate when [*][4] is entered on any keypad on any of the selected partitions.

PARTITION STATUS
(08)

The output will activate when any of the selected partitions are armed.

LATCHED STROBE
(09)

The output will activate when any alarm occurs on any of the selected partitions. The output will stay activated until the partition that caused the alarm is disarmed.

TROUBLE OUTPUT
(10)

The output will activate when a trouble condition is present on any of the selected partitions. If a system trouble occurs (i.e. loss of time, TLM) all trouble outputs will activate.

COURTESY PULSE
(11)

The output will activate during exit and entry delay on any of the selected partitions.

CHIME FOLLOWER
(12)

The output will activate when door chime is activated on any of the selected partitions, and deactivate when the chime pulse timer expires. (See "CHIME PULSE" under "PGM PULSE TIMES".)

Door chime activates when a zone is opened and activates again when a zone is closed. For Door Chime to activate, the user must enable the door chime (see "DOOR CHIME" under [*][6] User Functions in the System Manual) and the installer will enable door chime for the individual zones (see "CHIME FUNCTION" under "ZONE OPTIONS").

TLM ONLY (13)	The output will activate when a telephone line trouble is present.
TLM AND ALARM (14)	The output will activate when a Telephone Line Trouble is present and an alarm occurs on any of the selected partitions. The partition must be armed for the output to activate.
FAILURE TO COMM (15)	The output will activate when a Failure to Communicate failure is present. The output will stay activated until the trouble is cleared by the user or a successful communication is sent to the central station.
COMMS ACTIVE (16)	The output will activate while the panel is attempting to communicate with the central station.
GROUND START (17)	The output will activate for a programmable number of seconds before the panel attempts to communicate with the central station. See "PGM Pulse Times".
KISSOFF OUTPUT (18)	The output will activate for a programmable number of seconds after a successful communication to the central station. See "PGM Pulse Times".
COMBUS POWER (19)	This output will remain active at all times unless a system reset is ordered by the main panel.
READY STATUS (20)	The output will activate when all the zones in the partition are closed, and the partition is disarmed. If a zone opens or the partition is armed, the output will deactivate.
ZONE ALARM (21)	This output will annunciate when a selected zone has gone into alarm. Any one of the 128 zones can be selected. If the zone is armed and goes into alarm, the output will activate and remain active, even when the partition the zone belongs to has been disarmed. The output will remain active until the partition is armed again.
ZONE FOLLOW (22)	This output will follow a selected zone. Any one of the possible 128 zones can be selected. If the zone is opened, the output will activate. When the zone is closed the output will deactivate. See "Follows + Alarms" for enabling the output to be a zone follower and zone alarm annunciator.

RS-232 OPTIONS

RS-232 OPTIONS
(09)

This section will allow you to select the baud rate and handshake requirements for a PC4400 module if an on-site printer is being used.

BAUD RATE
(0)

The Baud Rate is the communications speed of the PC4400 module. The PC4400 can communicate at 300, 600, 1200, or 2400 baud. If the printer is experiencing problems with missing characters, try lowering the baud rate.

HANDSHAKE
(1)

This section is used to program the type of handshake signal used with the printer.

HANDSHAKE OFF
N

This selection is for printers that do not use handshakes.
YES = No handshake (XON/XOFF).
NO = A handshake signal is sent to the printer (DTR Protocol).

ADD/EDIT PARTITIONS

ADD/EDIT PAR

(0)

Add/Edit Partition. Default settings has only the first partition enabled. To enable more partitions, select the Add/Edit partition section, then select the partition. The partition is now enabled. To check if a partition is enabled or not, exit installer's programming, enter in a system master code and select the 'View Partitions' option. Only partitions which are enabled will be displayed.

WHICH PARTITION

(1) → (8)

The PC4000 can be divided into 8 partitions. This section selects which of the 8 partitions the installer is programming.

CUSTOMER ID CODE

(0)

Each partition has its own 4 digit customer account number that will be transmitted to the monitoring station when a reporting code is sent. The monitoring station can then identify the customer. Where a zero digit is required, use Hex A to transmit ten pulses. The receiver at the monitoring station interprets ten pulses as a zero. If a three digit code is required, enter [0] as the last digit. [0] represents a null digit, no pulses will be transmitted.

An account number must be programmed for each partition. If the system has several partitions and will report all events using the same account number then that account number must be programmed for each partition.

Partition Toggles

PAR TOGGLES

(1)

Enabling or disabling options for individual partitions.

Each toggle options is programmable by partition individually. For example, if door chime was desired on all partitions then that option must be enabled for all partitions.

[F] ENABLED

Y

YES = The [F]ire key is enabled.
NO = The [F]ire key is disabled.
(See "KEYPAD TOG OPT".)

[A] ENABLED

Y

YES = The [A]uxiliary key is enabled.
NO = The [A]uxiliary key is disabled.
(See "KEYPAD TOG OPT".)

[P] ENABLED

Y

YES = The [P]anic key is enabled.
NO = The [P]anic key is disabled.
(See "KEYPAD TOG OPT".)

DISPLAY CLOCK

Y

YES= The time and date will be displayed on every keypad of the partition instead of the "ENTER CODE TO ARM SYSTEM" message after 10 seconds of no key presses.
NO = No clock display.

DISP EXIT TIME

Y

YES= The exit delay time remaining will be displayed in the lower corner on all keypads on the partition during the exit delay.
NO = No exit time display.

BYPAS REQ CODE

Y

Bypass require code?
YES= Bypassing zones requires a valid access code ([*][1][code]). Either a system master or an access code assigned to that partition.
NO = No access code required to bypass zones. ([*][1])

AUTOARM ENAB

Y

YES = Auto Arm control enabled.
NO = Auto Arm control disabled. If disabled, the user will not be able to enter the Auto Arm control menu in the [*][6] user functions.

ABORT REQ CODE

N

YES= An access code must be entered during the auto-arm pre-alert to abort the auto-arm.
NO = Pressing any key during the pre-alert will abort the auto-arm.

- | | |
|----------------------------|---|
| BELL SQUAWK ON
N | YES = The bell output will activate once briefly when the partition is armed, twice when disarmed. Only the bell terminals on the PC4000 main board, when programmed for "Fire and Burg", "Inv Fire/Burg", "Burg Only" or "Inv Burg Only", will squawk.
NO = Bell Squawk disabled. |
| KYPD LOCKOUT?
N | YES= Keypad Lockout enabled.
NO = Keypad Lockout disabled.
(See "TOTAL BAD CODES", "LOCKOUT DURATION" and "LOCKOUT REP CODE".) |
| UTIL REQ CODE
N | YES= Utility output requires a valid access code - [*][7][access code].
NO = No access code required - [*][7].
(See "UTILITY OUTPUT".) |
| SEN RES REQ CD
N | YES= Sensor Reset Requires Code - [*][4][access code].
NO = Sensor Reset does not require a code - [*][4].
(See "SENSOR RESET".) |
| USER FN ANY CD
Y | YES= User functions require [*][6][any code].
NO = User functions require [*][6][Master Code]. This means a Grand Master, System Master or a Partition Master Code assigned to that partition. |

Partition Times

- | | |
|-------------------------------|---|
| PARTITION TIMES
(2) | The following programming sections are for programming various times separately for each partition. |
|-------------------------------|---|

You must program entry/exit delay times for each partition on the system.

- | | |
|-------------------------------|---|
| ENTRY DELAY
(0) | The keypads will give a tone to signal an entry delay when a Standard Delay zone or a Delay Home Away zone is activated. This gives the user time to disarm the system when they enter through a door. The entry delay time is programmable from 000 to 255 seconds. (See Standard Delay zones and Delay Home Away zone types). |
| EXIT DELAY
(1) | When a system is armed, the zones will not become active until the exit delay has expired, this gives the user time to exit the building without tripping alarms. The exit delay time is programmable from 000 to 255 seconds. This time can be displayed on the keypad (See "DISP EXIT TIME"). |
| AUX ENTRY DELAY
(2) | This entry time is for auxiliary delay zones, for doorways that may need a longer or shorter entry delay than standard delay zones. This time is programmable from 000 to 255 seconds (See Auxiliary Delay zone types). |
| AUX EXIT DELAY
(3) | This exit time is for auxiliary delay zones, for doorways that may need a longer or shorter exit delay than standard delay zones. This time is programmable from 000 to 255 seconds. (See Auxiliary Delay zone types) |

ADD/EDIT ZONES

Zone Assignment

ZONE ASSIGNMENT (3)

This section is for assigning type, options and reporting codes for each individual zone.

COMMON ZONES. Any zone can be assigned to 2 or more partitions. The zone will not be armed until all partitions it has been assigned to are armed. Once any partition the zone is assigned to is disarmed the zone will also be disarmed. This can be useful when there is a common entry point to 2 or more partitions.

A common zone will NOT be armed and will NOT go into alarm unless all partitions it is assigned to are armed.

ADD NEW ZONE (0)

By default, the first 16 zones on the main panel are assigned to partition 1. If zone expanders have been enrolled, the zones must be added to a partition for the PC4000 to be able to monitor them.

Upon entering this section, the zones which have not been assigned to the selected partition will be displayed. Use [<][>] keys to toggle through the zones, and the [Q] key to select which zone to add to the selected partition.

When zones are added to the system by enrolling additional zone expansion modules, the zones are not assigned to any partition. The additional zones must be added to the proper partition.

EDIT ZONE (1)

This section is for editing zones which have already been assigned to a partition. Upon entering this section, the zones which have been assigned to the selected partition will be displayed. Use the [<][>] keys to toggle through the zones, and the [★] key to select the zone to edit.

ZONE LABEL (0)

Each zone can have its own unique label to help identify it on the LCD keypad. Upon first entering this section, the LCD will display the zone number and the current zone label. Press the [★] key to continue into the zone label menu.

Each zone label is made up of two words. Both words are taken from the library of 255 words in the PC4000's memory. See appendix B for a list of the library words.

Note that the last 32 words (224-255) of the library are programmable for personalizing the zone labels.

See "CUSTOM ZONE ID" under LCD messages for programming the 32 custom labels.

Be careful when selecting the two words that make up the zone label. The keypad can only display 15 letters. If the two words combined are longer than 15 letters, everything after the 15th letter will be cut off.

The PC4000 provides a library of 224 factory programmed words for programming zone labels. In addition 32 custom words may be programmed. Any words required are not in the factory library must be programmed as one of the 32 custom words.

ZONLAB 1ST WORD (0)

This section is for selecting the first word of a zone label. Valid entries are from 000 to 255. See Appendix B for a listing of the 255 words available.

If this section is programmed with 000 and "ZONLAB 2ND WORD" is programmed with 000, the zone label will be the zone number.

For example, if zone 21 was programmed with 000 for both label words, the label would be "ZONE 21". This is the default setting for all zones.

ZONLAB 2ND WORD (1)

This section is for selecting the second word of a zone label. Valid entries are from 000 to 255. See Appendix B for a listing of the 255 words available.

If only one word is needed for a zone label, use the first word and leave the 2nd word as 000. Be careful when selecting two words, only a total of 16 letters can be entered. Everything after the 16th letter will be cut off.

Zone Type

ZONE TYPE
(1)

Select the zone type for the selected zone. Upon entering this section, the current programmed zone type is displayed.
For example, zone 001 will display "STANDARD DELAY" the first time it is programmed. The default setting is for Standard Delay. All other zones (002 through 128) are instant zones by default.

If and when you change a zone type, the "Zone Options" will default to the options found in the table below.

Zone Options

Zone Type Default Settings

Bell Audible	Y	Y	Y	Y	Y	Y	Y	Y	Y	Y	Y	Y	Y	Y	Y	Y
Bell Pulsed	N	N	N	N	N	N	N	N	N	Y	Y	Y	N	N	N	N
Bypass Enabled	Y	Y	Y	Y	Y	Y	Y	Y	Y	N	N	N	Y	Y	N	Y
Chime Function	Y	Y	Y	N	N	N	N	N	N	N	N	N	N	N	N	N
Force Arm	N	Y	N	N	N	N	N	N	N	N	N	N	N	N	N	N
Swgr Shut Down	Y	Y	Y	Y	Y	Y	N	N	N	N	N	N	N	N	N	Y
Tx Delay ?	N	N	N	N	N	N	N	N	N	N	N	N	N	N	N	N

For example, if zone 009 is programmed for zone type "24 HR BUZZER", the zone options "BELL AUDIBLE" and "BYPASS ENABLED" will be enabled, and all other options will be disabled for zone 009.

STANDARD DELAY
(00)

Standard delay zones have an entry and exit delay. The exit delay starts as soon as the panel is armed. The loop may be opened and closed during the delay time without causing an alarm. After the exit delay time has expired, opening the loop will start the entry delay timer. During the entry delay time, the keypad will sound steadily to advise the user that the system should be disarmed. If the panel is disarmed before the entry time expires, no alarm will be generated.

AUXILIARY DELAY
(01)

The auxiliary delay zone operates the same way as the standard delay zone. However different entry/exit times may be programmed. This is useful when a system has two delay zones, each requiring a different entry/exit time.

INSTANT
(02)

The zone opened will activate instantly after the partition is armed and the exit delay has expired.

INTERIOR
(03)

The zone will follow the entry time of a delay zone. If no delay zone has been tripped the zone will activate instantly.

INT HOME AWAY
(04)

The zone will operate the same as the interior option with one exception: the zone will automatically bypass if no delay zone on the partition is tripped during exit delay.

DELAY HOME AWAY
(05)

The zone will operate the same as the Interior Home/Away option with one exception: the zone has entry delay.

24 HR BELL
(06)

A 24 Hour Bell zone is active at all times, and will create an alarm whether the partition is armed or disarmed. This zone will not go into alarm if the zone is bypassed.

24 HR BELL/BUZZ (07)	This zone operates like the 24 hour bell option except the bell output terminals are activated when the partition is armed, and the keypad buzzer will be activated when the partition is disarmed.
24 HR BUZZER (08)	Operates the same as the 24 hour bell, except this zone will only activate the keypad buzzer.
STANDARD FIRE (09)	A fire zone is a 24 Hour zone that is specially used for fire detection circuits. On alarm, the bell output will pulse the bells to indicate that the fire loop has been activated. The communicator will immediately transmit the alarm to the monitoring station. If the fire zone is open circuit, the keypads will beep every 10 seconds and a fire zone trouble will be displayed on the LCD. If programmed the communicator will transmit the trouble to the monitoring station. The keypad beeping may be silenced by pressing the [#] key.
DELAYED FIRE (10)	This fire zone works the same way as a 24 Hour fire zone, except the alarm memory and transmission by the communicator is delayed by 30 seconds. If the alarm is acknowledged by pressing the [#] before the 30 second delay expires, the bells will silence and the transmission will be aborted. If after the alarm has been acknowledged, and the smoke detector has not been restored to normal, after 90 seconds the bell output will be activated again, in which the user then has another 30 second delay before the bell output latches and communicator are activated. A code would then be required to silence the bell output.
AUTO VER FIRE (11)	Automatically Verifying Fire Zone. This zone works the same way as the Standard Fire Zone with the exception that it will reset the smoke detectors and wait for it to go into alarm again before sounding the bells and transmitting the alarm to the monitoring station. If the smoke detectors do not go into alarm again, it assumes there is a false alarm and no fire alarm will be initiated. For activating an automatically verifying fire zone, the smoke detectors must be powered by the SW AUX power supply on the main panel, or controlled by a relay on a PC4204 module. Otherwise the PC4000 has no control over the power to the sensors. When an automatically verifying fire zone is opened, the PC4000 performs a "SENSOR RESET", which removes the power from the smoke detectors for 20 seconds. All SW AUX, BELL or PGM outputs programmed for "SENSOR RESET" will activate. The outputs will activate for 20 seconds, regardless of the time programmed in the "PGM PULSE TIMES" section. After 20 seconds, power will be restored to the sensors. If the smoke detectors initiate another alarm within 60 seconds after the power is restored, a fire alarm will immediately sound and the monitoring station will be notified. If the smoke detector is not reset during the sensor reset, the zone will not be restored. Because the zone is not restored, no fire alarm will be initiated. See PGM OUTPUTS for programming an output as "SENSOR RESET", "Smoke Detector Power Supply" on the PC4204 Wiring Diagram for using the PC4204 to power up the smoke detectors, and PC4000 Wiring Diagram in the System Manual for using the SW AUX on the main panel to power up the smoke detectors.
MOMENTARY ARM (12)	A momentary closure of this zone will alternately arm and disarm the partition. This zone can be used as a key switch to arm and disarm the system. The zone is monitored for End of Line resistors if the "ZONES EOL" option is enabled in the system options.
MAINTAINED ARM (13)	When the zone is closed the partition will disarm. When the zone is opened the partition will be armed. The zone is monitored for End of Line resistors if the "ZONES EOL" option is enabled in the system options.
LATCHING 24 HR (14)	The zone will operate the same as the 24 hour bell option with one exception: the installer's mode ([*][8]) must be entered before the system can be armed. This will ensure the problem has been examined by the installer.
FORCED ANSWER (15)	When this zone is tripped, the panel will instantly pick up the phone lines looking for a downloading computer. Do not use this zone type to monitor for alarms.

Zone Options

If and when you change a zone type, the "Zone Options" will default to the options found in the table below.

BELL AUDIBLE Y	YES= An alarm causes the bell output to activate. NO = Silent alarm.
BELL PULSED N	YES= The bell output will pulse when the zone is in alarm. NO = The bell output will be steady when the zone is in alarm.
BYPASS ENABLED Y	YES= The zone may be manually bypassed. NO = The zone cannot be bypassed.
CHIME FUNCTION Y	YES= Every keypad on the partition will chime both when the zone is violated and when the zone is then secured. The partition must be disarmed for the chime option to function. NO = The zone will not chime the keypads.
FORCE ARM N	YES= The partition may be armed with the zone violated. The zone will be temporarily bypassed, and when the zone is secured it will be added back into the system. NO = The partition cannot be armed if this zone is open.
SWGR SHUT DOWN Y	YES= After a zone causes a programmed number of alarms, the zone will shut down so that no further transmissions are sent to the monitoring station. The bell can follow swinger shut down if programmed. (See "SHUT DOWN 24HRS", "SWINGER LIMIT" and "BELL SHUT DOWN".) NO = Swinger shut down disabled.
TX DELAY ? N	YES= The reporting of zone alarm will be delayed for the programmed time. If the system is disarmed within this time, no alarm signal will be communicated. (See "ZONE TX DELAY".) NO = When an alarm occurs, the reporting code is transmitted immediately.

Reporting Codes

REP CODES (3)	These are the reporting codes transmitted to the monitoring station for the selected zone. They are the same as the zone alarm and zone restoral reporting codes programmed in the communicator section of the system area.
ALARM REPCODE (0)	This is a 2 digit alarm reporting code for the zone being added to the partition.
RESTORE REPCODE (1)	This is the 2 digit restoral reporting code for the zone being added to the partition.

DELETE ZONE

DELETE ZONE

(2)

Deleting zones from the partition. When selecting which zone to delete, the keypad will only display zones which are assigned to the partition.

When the PC4000 is first powered up, the 16 zones on the main panel are assigned to partition 1. If any of these zones are to be assigned to a different partition they must be deleted from partition 1.

PAR NAME LABEL

(4)

Programming a partition name label. This label is programmed in the same manner as LCD messages or custom zone ID (see "Custom Zone ID").

DELETE/COPY PARTITION

DELETE PARTITION
(1)

Disables a partition.
If a partition is deleted, it does not erase any programming or remove any zones assigned to it, so if the installer decides to re-enable the partition, the programming is still there.

COPY PARTITION
(2)

Copies a partition.
Copies the programming from one partition to another one. This includes the Customer ID Code, Partition Toggles, Partition Times and the Partition Name Label. The zone assignment is not copied.

MODULE HARDWARE

Enroll Module

When the system is first powered up it is not aware of any module connected to it. Each module must be enrolled through Installer's Programming before the panel will communicate with it. Do not connect or disconnect any module from the COMBUS if power is connected to the system.

ENROLL MODULE (0)

All keypads connected to the system will display 'PC4000 DSC Ltd.' on the first line. The software version of the keypad and the date will appear on the second line.

The first keypad on which you press a key will automatically be enrolled in the system as keypad module number 01. It will also be assigned to partition 1. The first keypad on which you press a key must be a keypad that is intended to be in partition 1.

LCD4500 KEYPADS (0)

TO ENROLL ADDITIONAL KEYPADS. Use the [<][>] keys to scroll through the Enroll Module menu and when 'LCD 4500 Keypads' is displayed press the [★] key. You will be prompted to press any key on the desired unit. After pressing any key return to the original keypad. It will prompt you for the Partition which the keypad is to be assigned. Use the [<][>] keys to scroll through the eight Partitions and when the desired Partition is displayed press the [★] key. The keypad is now enrolled in that partition.

The module number, location and partition, to which the keypad has been assigned should be noted on the 'System Overview' found in the PROGRAMMING WORK SHEETS book.

If a keypad is assigned to the wrong partition it will have to be deleted and then re-enrolled to the proper partition.

PC41XX ZONE EXP (2)

TO ENROLL ADDITIONAL ZONE EXPANDERS. Use the [<][>] keys to scroll through the Enroll Module menu until 'PC41XX MODULE' is displayed and press the [★] key to select the item. The keypad will now display 'CREATE TAMPER ON DESIRED UNIT'. Trip and restore the Tamper zone and when you return to the keypad it will display the module number. Press the [>] key and the keypad will display the zones assigned to the expander. The module number, zones assigned and location of the module should be noted on the 'System Overview' found in the PROGRAMMING WORK SHEETS book.

Zones 1 through 16 are located on the main panel. When expander modules are enrolled zones are added to the system in sequence. For example, if two 8 zone expanders (PC4108 modules) were enrolled the first would be assigned zones 17-24, the second zones 25-32.

When zones are added to the system they are not assigned to any partition. They must be assigned to the proper partition in Partition Area programming.

The AUX+ and AUX- terminals on all zone expansion modules can be used to provide power to PIR's, glassbreak detectors etc... DO NOT connect these terminals to the AUX+ and AUX- of the main panel.

PC4204 4 O/P**(4)**

TO ENROLL PC4204 MODULES. Use the [<][>] keys to scroll through the Enroll Module menu until 'PC4204 MODULE' is displayed and press the [★] key to select the item. The keypad will now display 'CREATE TAMPER ON DESIRED UNIT'. Trip and restore the tamper zone and when you return to the keypad it will display the module number. This number and the location of the module should be noted on the 'System Overview' found in the PROGRAMMING WORK SHEETS book.

PC4216 16 O/P**(3)**

TO ENROLL PC4216 MODULES. Use the [<][>] keys to scroll through the Enroll Module menu until 'PC4216 MODULE' is displayed and press the [★] key to select the item. The keypad will now display 'CREATE TAMPER ON DESIRED UNIT'. Trip and restore the Tamper zone and when you return to the keypad it will display the module number. This number and the location of the module should be noted on the 'System Overview' found in the PROGRAMMING WORK SHEETS book.

PC4400 RS-232**(1)**

TO ENROLL THE PC4400 MODULE. Use the [<][>] keys to scroll through the Enroll Module menu until 'PC4400 MODULE' is displayed and press the [★] key to select the item. The keypad will now display 'CREATE TAMPER ON DESIRED UNIT'. Violate and restore the Tamper zone and when you return to the keypad it will display the module number. This number and the location of the module should be noted on the 'System Overview' found in the PROGRAMMING WORK SHEETS book.

Delete Module

DELETE MODULE**(1)**

The PC4000 memorizes each module on the system. When a module is removed, it must be deleted from memory.

If a module has been enrolled out of sequence it will have to be deleted from the system and then re-enrolled in the proper order. Use the "Confirm Module" function to verify the module number before deleting it from the system.

Confirm Module

CONFIRM MODULE**(2)**

Identify a module on the system in case the module number has been lost and further programming on that module is desired. Once the tamper is created the LCD4500 display will indicate the module number.

EVENT BUFFER

EVENT BUFFER**(3)**

The installer can review the events stored in the event buffer by sending the contents of it to a printer.

PRN ENTIRE BUFF**(0)**

Printing out the event buffer through the PC4400 module. All events stored in the event buffer will be printed out. The event buffer can store up to 512 events.

The event buffer always contains the last 512 events that have occurred on the system. It cannot be erased.

NOTE: If the printer is left on line hooked up to the PC4400 (RS-232) module, it will always print out events as they occur.

DIAGNOSTICS

DIAGNOSTICS

(4)

The Diagnostics function helps the installer to track down any problems that may be occurring with the modules. If this section is entered during the first minute after powering up the system, the selections Diagnostics, Binary Program, Memorize Vbat and Factory Default will be available to the installer. After the first minute, Diagnostics will automatically be selected.

DIAGNOSTICS

(0)

The Diagnostics function helps the installer to track down any problems that may be occurring with the modules.

If there is no problem the keypad will display 'PC4000 System No Faults Found'. If there is a problem, the keypad will display 'Error ... Module' along with 'E- T- LV-' and a number following one of them. The number represents a module (See Appendix C). The 'E' stands for a communications error, if the number follows the 'E', the main panel has lost communications with the module represented by the number. The 'T' stands for tamper, which means the tamper zone on the module has been activated. The 'LV' stands for low voltage, for when the module is not receiving enough voltage from the combus. For example, if the display shows 'E- T-25 LV- ', this means the tamper on the PC4400 RS-232 module has been activated. The [<][>] keys are used to toggle the display if there is more than one module with a trouble.

NOTE: The following items are available during the first minute after power up.

BINARY PROGRAM

(1)

Normally used upon instruction from factory technical personal for specialized programming not covered by the standard programming instructions.

MEMORIZE VBAT

(2)

Programs the battery offset voltage. Normally this is already set at the factory and need not be done again. To set the VBAT = 13.85 volts, remove the battery from the battery terminals. The battery terminals should now be output 13.85 volts. If it's not 13.85, turn the 'pot' below the heatsink until the voltage is the correct value. (If the voltage is 0 volts, check the battery fuse).

FACTORY DEFAULT

(3)

The programming keypad will display the message 'Power System Down and Restart'. Remove all power to the main panel. This will erase all programming and reset the system to factory default settings. All modules will have to be re-enrolled.

APPENDIX A

Zone Label Library

List of Available Library Words

000 BLANK LABEL	037 "CELLAR"	074 "ENTRANCE"	111 "JANITOR"
001 "1ST"	038 "CENTRE"	075 "ENTRY"	112 "KEY"
002 "2ND"	039 "CHAMBER"	076 "EXIT"	113 "KITCHEN"
003 "3RD"	040 "CHIMNEY"	077 "EXTERNAL"	114 "LAB"
004 "4TH"	041 "CHINA"	078 "FACTORY"	115 "LAUNDRY"
005 "5TH"	042 "CHUTE"	079 "FAMILY"	116 "LEFT"
006 "ACCESS"	043 "CLOSET"	080 "FENCE"	117 "LIFT"
007 "AMBULANCE"	044 "COLD"	081 "FIELD"	118 "LIGHT"
008 "APARTMENT"	045 "COMPUTER"	082 "FIRE"	119 "LINES"
009 "ATRIUM"	046 "CONDO"	083 "FLOOD"	120 "LIQUOR"
010 "ATTIC"	047 "CONTACT"	084 "FLOOR"	121 "LIVING"
011 "BABY"	048 "COPIER"	085 "FOIL"	122 "LOBBY"
012 "BACK"	049 "CORRIDOR"	086 "FORCE"	123 "LOFT"
013 "BALCONY"	050 "CORNER"	087 "FOYER"	124 "LOOP"
014 "BAR"	051 "CRAWL"	088 "FRONT"	125 "LOT"
015 "BARN"	052 "DARK"	089 "FULL"	126 "LOW"
016 "BASEMENT"	053 "DECK"	090 "FURNACE"	127 "LUNCH"
017 "BATHROOM"	054 "DEN"	091 "FUSE"	128 "MACHINE"
018 "BAY"	055 "DESK"	092 "GARAGE"	129 "MAIL"
019 "BEAM"	056 "DETECTOR"	093 "GAS"	130 "MANAGER"
020 "BEDROOM"	057 "DEVICE"	094 "GATES"	131 "MASTER"
021 "BELL"	058 "DINING"	095 "GLASS"	132 "MEDICAL"
022 "BOILER"	059 "DISH"	096 "GROUP"	133 "MEETING"
023 "BOTTOM"	060 "DISPLAY"	097 "GUARD"	134 "MIDDLE"
024 "BOX"	061 "DOOR"	098 "GUEST"	135 "MODULE"
025 "BREAK"	062 "DOORBELL"	099 "GUNS"	136 "MOTION"
026 "BROKEN"	063 "DOWNSTAIRS"	100 "GYM"	137 "N E"
027 "BURGLARY"	064 "DRAWER"	101 "HALLWAY"	138 "N W"
028 "CABINET"	065 "DRIVEWAY"	102 "HEAT"	139 "NORTH"
029 "CAFE"	066 "DRY"	103 "HOSE"	140 "NURSERY"
030 "CAGE"	067 "DUCTS"	104 "HOT"	141 "OFFICE"
031 "CAMERA"	068 "DUPLEX"	105 "HOUSE"	142 "OUTSIDE"
032 "CARPORT"	069 "EAST"	106 "HUMIDITY"	143 "OVER"
033 "CASH"	070 "ELECTRIC"	107 "INNER"	144 "OVERFLOW"
034 "CASHIER"	071 "ELEVATOR"	108 "INSIDE"	145 "OVERHEAD"
035 "CEILING"	072 "EMPTY"	109 "INTERCOM"	146 "PAD"
036 "CELL"	073 "EMERGENCY"	110 "INTERNAL"	147 "PANEL"

NOTE: 000 is a blank label for the "2ND" word, and is 'Zone XXX' for the "1ST" word.

148 "PANIC"	167 "REC"	186 "SOLAR"	205 "UNIT"
149 "PARKING"	168 "REGISTER"	187 "SOLARIUM"	206 "UPSTAIRS"
150 "PASSIVE"	169 "RIGHT"	188 "SOUTH"	207 "UTILITY"
151 "PATIO"	170 "ROOF"	189 "SPACE"	208 "VAULT"
152 "PHONE"	171 "ROOM"	190 "SPARE"	209 "VOLTAGE"
153 "PHOTO"	172 "ROOT"	191 "SPRINKLER"	210 "WAITING"
154 "PIPES"	173 "S E"	192 "STABLE"	211 "WALKWAY"
155 "PIR	174 "S W"	193 "STAIRS"	212 "WAREHOUSE"
156 "PLACE"	175 "SAFE"	194 "STORAGE"	213 "WATER"
157 "PLATE"	176 "SCREEN"	195 "STORE"	214 "WELL"
158 "PLAY"	177 "SENSOR"	196 "STRIKE"	215 "WEST"
159 "POLICE"	178 "SHED"	197 "STROBE"	216 "WINDOW"
160 "POOL"	179 "SHELF"	198 "STUDY"	217 "WINE"
161 "PORCH"	180 "SHIPPING"	199 "TABLE"	218 "WING"
162 "POWER"	181 "SHOP"	200 "TAMPER"	219 "WIRE"
163 "PREMISE"	182 "SIDE"	201 "TEMP"	220 "WIRELESS"
164 "PRESSURE"	183 "SIREN"	202 "TOOLS"	221 "WORK"
165 "RADIATOR"	184 "SLIDING"	203 "TOP"	222 "WORKSHOP"
166 "REAR"	185 "SMOKE"	204 "UNDERGND"	223 "YARD"

Custom Zone ID

224 "_____"	240 "_____"
225 "_____"	241 "_____"
226 "_____"	242 "_____"
227 "_____"	243 "_____"
228 "_____"	244 "_____"
229 "_____"	245 "_____"
230 "_____"	246 "_____"
231 "_____"	247 "_____"
232 "_____"	248 "_____"
233 "_____"	249 "_____"
234 "_____"	250 "_____"
235 "_____"	251 "_____"
236 "_____"	252 "_____"
237 "_____"	253 "_____"
238 "_____"	254 "_____"
239 "_____"	255 "_____"

List of Available ASCII Characters

032	048	064	080	096	112	160	176	192	208	224	240
!	1	A	Q	a	q	6	7	8	9	:	;
033	049	065	081	097	113	161	177	193	209	225	241
"	2	B	R	b	r	r	8	9	0	1	2
034	050	066	082	098	114	162	178	194	210	226	242
#	3	C	S	c	s	l	9	0	1	2	3
035	051	067	083	099	115	163	179	195	211	227	243
\$	4	D	T	d	t	\	0	1	2	3	4
036	052	068	084	100	116	164	180	196	212	228	244
%	5	E	U	e	u	.	1	2	3	4	5
037	053	069	085	101	117	165	181	197	213	229	245
&	6	F	V	f	v	0	1	2	3	4	5
038	054	070	086	102	118	166	182	198	214	230	246
'	7	G	W	g	w	7	8	9	0	1	2
039	055	071	087	103	119	167	183	199	215	231	247
(8	H	X	h	x	8	9	0	1	2	3
040	056	072	088	104	120	168	184	200	216	232	248
)	9	I	Y	i	y	9	0	1	2	3	4
041	057	073	089	105	121	169	185	201	217	233	249
*	:	J	Z	j	z	E	0	1	2	3	4
042	058	074	090	106	122	170	186	202	218	234	250
+	;	K	[k	[0	1	2	3	4	5
043	059	075	091	107	123	171	187	203	219	235	251
,	<	L]	l	l	1	2	3	4	5	6
044	060	076	092	108	124	172	188	204	220	236	252
-	=	M	_	m)	2	3	4	5	6	7
045	061	077	093	109	125	173	189	205	221	237	253
=	>	N	^	n	0	3	4	5	6	7	8
046	062	078	094	110	126	174	190	206	222	238	254
/	?	O	_	o	0	4	5	6	7	8	9
047	063	079	095	111	127	175	191	207	223	239	255

APPENDIX B

Diagnostics Chart

E = Communication error
 T = Tamper open
 LV = Low voltage to module

Indicated # Number	For Future Use
-----------------------	----------------

1
2
3
4
5
6
7
8

Indicated Number	LCD4500 Module #
---------------------	---------------------

9 1
10 2
11 3
12 4
13 5
14 6
15 7
16 8
17 9
18 10
19 11
20 12
21 13
22 14
23 15
24 16

Indicated Number	PC4400 RS-232 Module #
---------------------	---------------------------

25 1

Indicated Number	PC41XX Zone Module #
---------------------	-------------------------

26 1
27 2
28 3
29 4
30 5
31 6
32 7
33 8
34 9
35 10
36 11
37 12
38 13
39 14
40 For future use15
41 For future use16

Indicated Number	PC4216 O/P Module #
---------------------	------------------------

42 1
43 2
44 3
45 4
46 5
47 6
48 7
49 8
50 9

Indicated Number	PC4204 O/P Module #
---------------------	------------------------

51 1
52 2
53 3
54 4
55 5
56 6
57 7
58 8
59 9
60 10
61 11
62 12
63 13
64 14
65 15
66 16

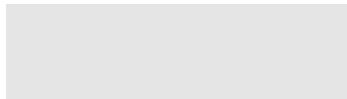

APPENDIX C

Calculating Line Loss

Below are additional quick reference graphs for the line loss of different gauge wire.

16 Gauge Wire

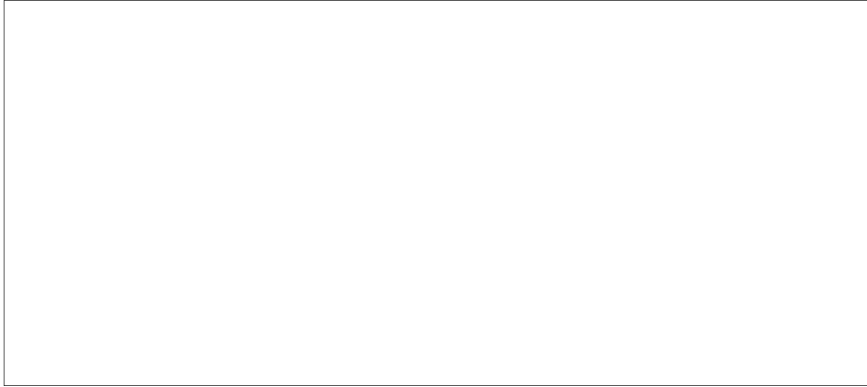

18 Gauge Wire

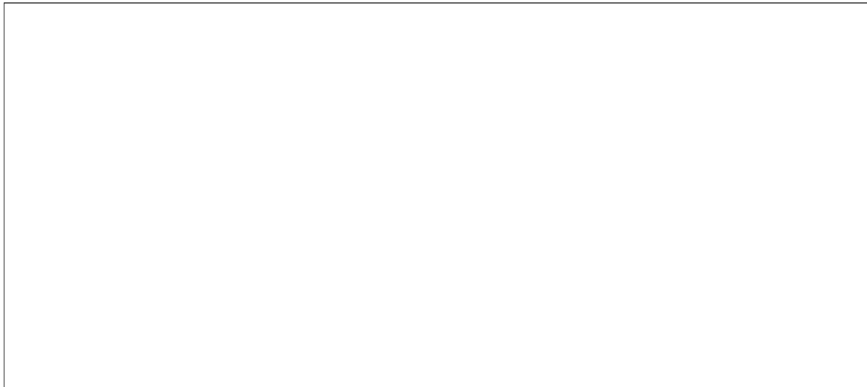

24 Gauge Wire

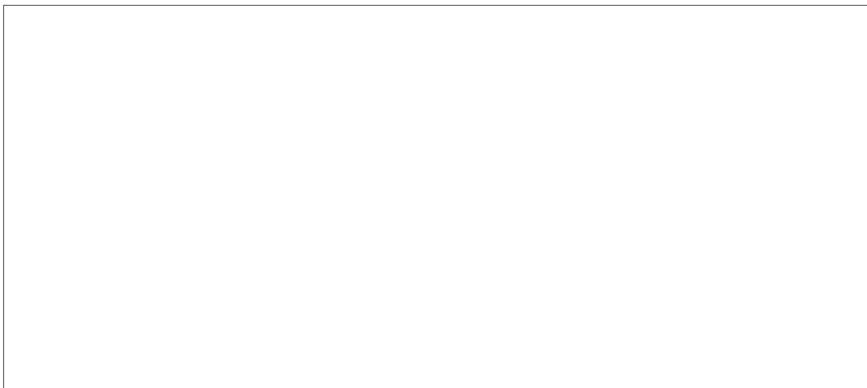

Advanced Method for Calculating Line Loss

The graphs are the quickest method for determining if the line loss on a wire run will require you to connect a PC4204 module for additional power. However you can perform your own calculations using the following method:

The formula for calculating the line loss in volts is as follows:

length of run in feet x 2 x resistance of wire x current Amps

The length of the run is multiplied by two because current must flow to the module and then back again.

The following is a chart of resistance for different gauge wires:

14 AWG - .00252 ohms/foot

16 AWG - .00402 ohms/foot

18 AWG - .00639 ohms/foot

22 AWG - .0162 ohms/foot

24 AWG - .0257 ohms/foot

The following is an example for calculating the line loss (22 AWG wire used)

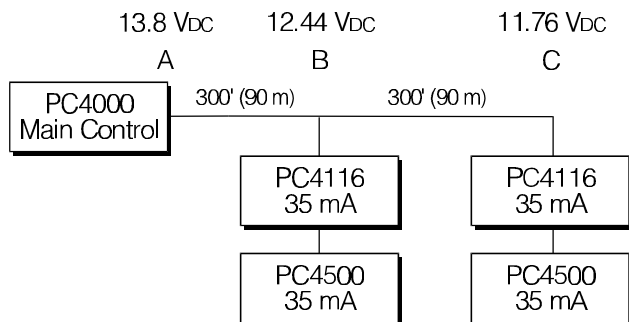

The line loss from point A to point B would be 1.36 VDC.

$$(300' / 90 \text{ m} \times 2) \times 0.0162 \times 0.14 \text{ A} = 1.36 \text{ VDC}$$

The current is 140 mA (0.14 A) because the current for all the modules will flow on the wire run between point A and point B.

The line loss from point B to point C would be 0.68 VDC.

$$(300' / 90 \text{ m} \times 2) \times 0.0162 \times 0.070 \text{ A} = 0.68 \text{ VDC}$$

The current flow is only 70 mA (0.07 A), the current required for the two modules connected at point C.

On the diagram the voltage at each point is located above the letter. A voltage of less than 12.5 VDC at a module is unacceptable as an extended interruption of the AC power source will cause the module to shut down (10 VDC) earlier than is acceptable.

To correct the problem a PC4204 should be connected in the following manner:

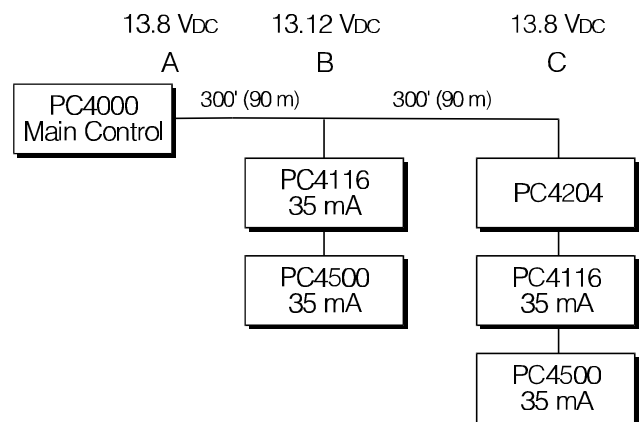

The line loss between point A and point B will be decreased because the current draw has been decreased to 70 mA (modules connected at point B). At point C there will be no appreciable line loss since the power supply module is in the same location as the modules being powered. The questionable voltage level at point B and the unacceptable voltage level at point C have both been corrected by the addition of one PC4204.

Important things to remember when calculating line loss:

1. The wire distance must be doubled since current must flow to the modules and then back again to form a complete circuit.
2. The current draw for each branch must be added if the current must flow through the same piece of wire.
3. Wires may be doubled up to increase the gauge and lower the line loss.

APPENDIX D

Event Buffer

The panel will automatically store all events that occur on the system into a 512 event buffer. These events can be uploaded via the DLS Downloading software or printed on site with the addition of a PC4400 module and a serial printer (See 'Printer Setup').

All events will also contain the date, time and the partition the event occurred on. All events that do not pertain to a particular partition (e.g. trouble conditions) will print 'System Area' instead of a partition number.

All events will indicate zone numbers, access code numbers or module numbers when applicable. In addition, if zone labels, access code labels or partition labels are programmed they will be printed on site.

The following is a list of all events that will be stored to the buffer. All events noted with a '*' will indicate the partition the event occurred on.

Zones

- Alarm/Restoral/Trouble by Zone*
- Keyswitch Log (stored when Keyswitch zone violated)*

Access Codes

- Opening/Closing by User*
- User Log by User*
- Opening After Alarm*
- Quick Arm*
- Quick Exit*
- Automatic Arming*
- Partial Closing*
- Downloading Arming/Disarming*
- Opening/Closing 2nd Master Code*

Main Panel Events

- Low Battery/Restoral
- AC Trouble/Restoral
- AUX Power Supply Trouble/Restoral
- Failure to Communicate Restoral
- Telephone Line Restoral
- COMBUS Communication Trouble/Restoral
- Power Up Warm
(COMBUS reset - followed by event Module Reset XX)
- Module Reset XX
(COMBUS reset - indicates module that initiated the reset)
- Power Up Cold (AC and Battery disconnected)
- Installer Lead In/Lead Out
- Periodic Test
- System Test*
(activated using [★], [6] Keypad Function)
- Software Reset
(panel reset through Installer's Programming)
- Hardware Reset
(panel reset by powering up with reset jumper wire)
- Downloading Lead In/Lead Out
- Buffer Near Full (Buffer is 75% Full)

Module Events

- Tamper Alarm/Restoral for all modules
- Low Battery/Restoral by PC4204 module
- AC Trouble/Restoral by PC4204 module
- AUX Trouble/Restoral by PC4204 module
- On Site Printer Trouble/Restoral

Keypads and Keypad Functions

- [F], [A], [P] Key Alarm/Restoral*
- Keypad Lockout*
- SW AUX by User*
(stored when [★], [4] Keypad function activated)
- Utility Output by User*
(stored when [★], [7] Keypad function activated)
- Bypass by User*
(stored when [★], [1] Keypad function activated)
- Auto Arm Abort Code by User*
(stored when Automatic Arming is aborted)
- System Master Menu by User*
(stored when [★], [6] Keypad function menu activated)

APPENDIX E

On Site Printer Setup

The PC4400 module is used for sending serial communications through an RS232 port to a local printer for on site monitoring of the PC4000.

All programming of the PC4400 is done through the PC4000.
The printer can be located up to 200 ft (61 m) away from the PC4400.
An 80 character printer is strongly recommended.

Configuring the Printer

1. Serial interface
2. Baud rate = 300, 600, 1200 or 2400 (PC4000 default setting = 1200 baud)
3. Parity = None
4. Character length = 8 bits
5. Auto line feed = Off
6. American/Canadian character set
7. DTR Protocol or XON/XOFF (by default the PC4000 sends DTR protocol)

The PC4400 comes complete with a DB-25 (male) modular jack adapter, and a 6 ft (2 m) six wire extension cord. A longer extension cord can be used if required, up to 200 ft (61 m) maximum.

Power down the PC4000, PC4400 and the printer.
Connect one end of the extension cord into the PC4400, and the other end into the DB-25 modular jack adapter.
Connect the DB-25 modular jack into the RS232 serial port of the printer.
See the PC4400 wiring diagram.

Power up the printer, then the PC4000 and PC4400. If the PC4400 is already enrolled and the printer is on line, the PC4400 will begin transmitting to the printer.

The following is a sample of a printout from the serial printer:

Partition Label	Date	Time	Event
System Area	05/26/94	11:01	HARDWARE DEFAULT
System Area	05/27/94	13:25	RS232 PRINTER ON LINE
Partition...2	05/27/94	15:00	ALARM ZONE 008
System Area	06/01/94	08:10	4204 #005 BATTERY TBL ALARM
System Area	06/02/94	08:13	Tamper LCD #001

Most actions on the PC4000 that require an access code are logged to the event buffer, and are sent to the printer. For example:

Partition...1	05/27/94	13:40	CLOSING ACCESS CODE 001
Partition...5	05/27/94	13:51	INSTALLER LEAD IN
Partition...4	05/29/94	15:30	UTIL OUTPUT CODE ACCESS CODE 054
Partition...1	06/01/94	08:05	SW AUX CODE ACCESS CODE 008
Partition...8	06/01/94	08:01	SYS MASTER MENU ACCESS CODE 002
Partition...1	06/02/94	23:59	BYPASS WITH CODE ACCESS CODE 004

The partition labels, access code names and zone labels can be changed in the PC4000. See "PAR NAME LABEL" in the Programming Manual for programming partition labels. See "EDIT CODE NAME" in the System Manual under [*][5] commands to program the access code names. See "ZONE LABEL" in the Programming Manual for programming zone labels. The printout will then be as follows:

```
West Plaza      06/04/94  02:05  CLOSING Head Custodian
Assembly Plant  06/04/94  02:09  ALARM Front Office
```

The PC4400 sends events to the printer as they occur.

If the printer is off line or disconnected, the PC4000 keeps new events in memory until they are able to be printed.

When the printer is brought back on line, the PC4400 will send the new events to the printer. If 384 new events occur before the printer is brought back on line (384 events = 75% of the buffer), the PC4000 will send the "Buf Near Full" reporting code to the monitoring station. (See 'Maint Rep Codes" in the Programming Flow Charts for programming the "Buf Near Full" reporting code). If over 512 events occur before the printer is brought back on line, the oldest events will be overwritten.

The PC4000 contains an event buffer which stores the last 512 events. To print out the entire event buffer, enter the "Prn Entire Buff" section in installers programming [*][8][Installer's Code][3][0]. The printout will begin with the oldest event in memory and end at the most recent one.

APPENDIX F

On Site Downloading Setup

Downloading is the use of an IBM compatible computer to program the PC4000 system. The computer can be located either on site, or communicate over the phone.

The DSC downloading package version 5.0 or later supports downloading to the PC4000.

See the downloading manual for details on specific capabilities and the "DLS" section in the PC4000 Programming Guide for programming DLS options.

Downloading over phone lines

Make sure the "TIP" and "RNG" terminals are connected to the phone line. Program the access code and the panel I.D. code in the PC4000.

The PC4000 panel can call the computer, or vice versa. "Ring Detect" or "User enabs DLS" must be enabled for the PC4000 to detect when the phone line is ringing, the time the computer is calling the panel.

The number of times the panel allows the phone line to ring before answering is programmable, and the default setting is 8 rings.

If the panel calls the computer, enable "User call up" and program the phone number of the computer. Initiate the call by entering [*][6][Master Code][7].

Downloading with an On-site Computer

Phone lines are not necessary to download to the panel if the computer is at the same location as the PC4000.

The tip and ring lines of the modem can be directly connected to the tip and ring terminals on the panel.

A DTS-1 must be connected to the lines and in the local mode.

Program the downloading access code and panel I.D. code.

Program a zone for "Forced Answer". See "Zone Type" in the Programming Guide. This zone is only meant to be temporary, to initiate downloading. It can later be changed back to the required zone type.

Make sure the access code and panel I.D. code are the same in the panel and computer. A telephone number must be programmed into the computer to initiate communications, and any number entries are accepted.

Activate the computer to call the panel. When the computer indicates "Dialing...No dial tone", press the dial tone button on the DTS-1 until the modem dialing the phone number is heard. Trip the zone programmed for "Forced Answer". The panel will seize the phone line and initiate communications with the computer. The computer will then display the message "Connected to panel..." and continue with communications.

The DTS-1 must remain connected to the phone line in local mode during the downloading.

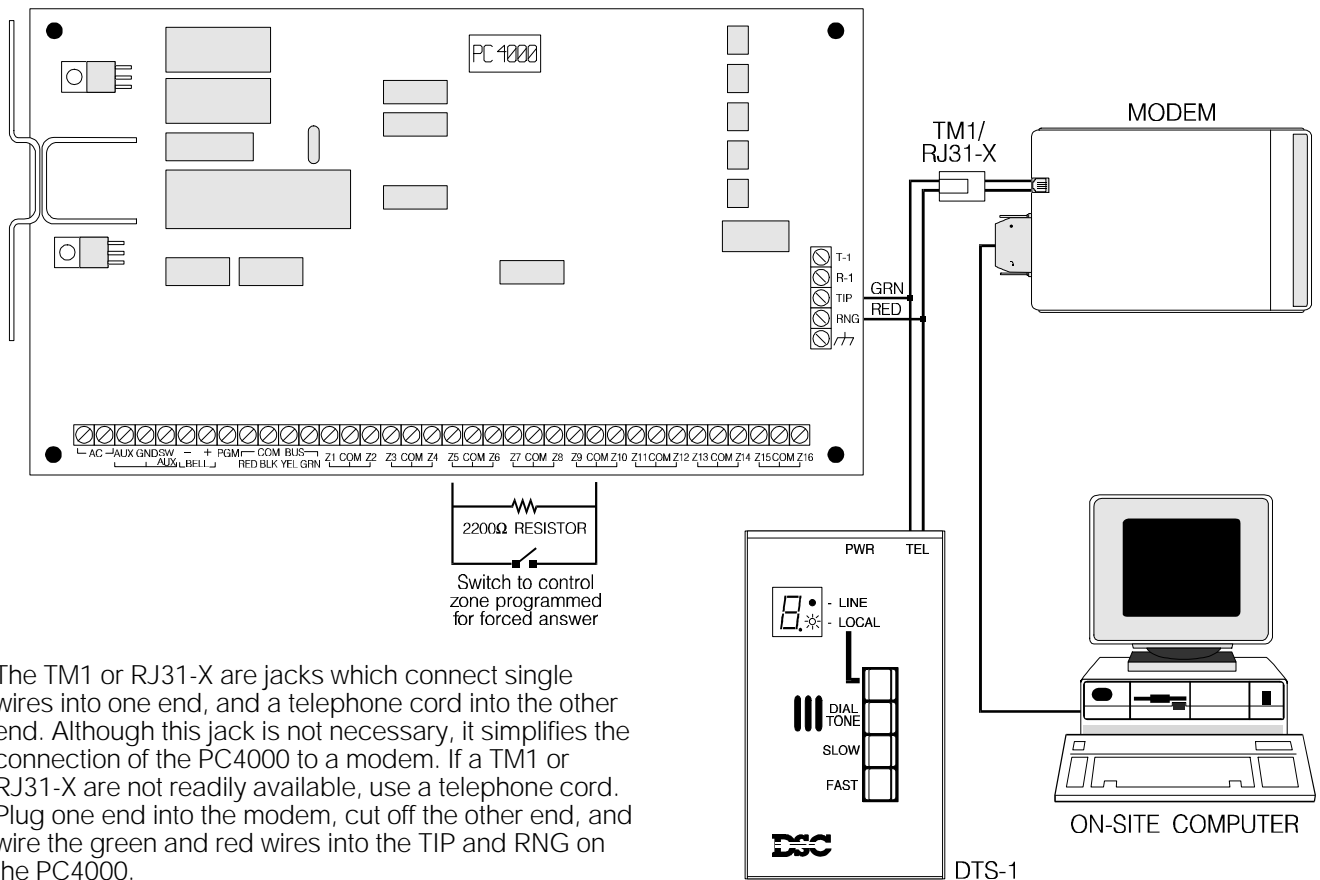

The TM1 or RJ31-X are jacks which connect single wires into one end, and a telephone cord into the other end. Although this jack is not necessary, it simplifies the connection of the PC4000 to a modem. If a TM1 or RJ31-X are not readily available, use a telephone cord. Plug one end into the modem, cut off the other end, and wire the green and red wires into the TIP and RNG on the PC4000.

APPENDIX G

Troubleshooting

Keypads

Problem	Solution
Keypad shows all dots or dashes	▶ Keypad is enrolled to a partition that has yet been defined
Keypad display has no backlighting	▶ Adjust backlight control using the [*] [6] command
Keypad blank, no response from keys	▶ No power to keypad ▶ Break in wire run to keypad ▶ Keypad is enrolled to a partition that has yet been defined

Communicator

Problem	Solution
Panel does not seize phone line	▶ Communicator disabled ▶ No reporting code programmed ▶ Call direction options for phone number all selected as 'No'
Panel dials, send signals, hangs up, then picks up the phone again	▶ Panel programmed to call 2 or more phone numbers - check call direction options for all numbers
Receiver gets errors	▶ Wrong format (handshake) ▶ Wrong account number ▶ Incorrect reporting codes
Panel sends wrong account number	▶ SIA format: a '0' in the account must be a '0' ▶ SESCOA : a '0' in the account must be a '0' ▶ All others: - a '0' in the account must be an 'A' - for a 3 digit account number the 4th digit must be a '0'

Power

Problem

Solution

Module shows low voltage trouble

- ▶ Voltage at module below 11.5 V_{DC}

To reduce line loss voltage:

- ▶ Decrease length of wire
- ▶ Increase gauge of wire
- ▶ Decrease current draw
- ▶ Use PC4204 power supply module

System resets power to modules often

- ▶ More than 500 mA being drawn from main panel
 - ▶ More than 100 mA being drawn from the AUX terminals of any expander
 - ▶ Less than 11.5 V_{DC} applied to any module on the system
 - ▶ COMBUS is run in parallel with output from siren driver
 - ▶ COMBUS run in shield
 - ▶ Wrong transformer connected to panel or PC4204 module: should be 16 - 18 V, 20 - 40 VA
-

INDEX

LCD Message

This index of messages is useful for those familiar with the operation of the system and need a quick reference. First enter [*][8][Installer's code], then the Quick Message Numbers for the option/function of interest.

Example:

AUX ENTRY DELAY, enter:

[*][8][4000] ▶ (1) ▶ (0) ▶ (1)→(8) ▶ (2) ▶ (2)

▶ indicates sequence of entries,
e.g. a number then(▶) the next.

→ indicates a range of entries from which one is
chosen, e.g. (1) to(→) (8).

T = Toggle

Symbols	Quick Message Numbers	Page
# OF RINGS	(0) ▶ (04) ▶ (6)	13
[A] AUD BUZZ	(0) ▶ (03) ▶ (1) ▶ T	10
[A] ENABLED	(1) ▶ (0) ▶ (1)→(8) ▶ (1) ▶ T	35
[A] SIL BELL	(0) ▶ (03) ▶ (1) ▶ T	10
[A] STDY BELL	(0) ▶ (03) ▶ (1) ▶ T	10
[F] BELL	(0) ▶ (03) ▶ (1) ▶ T	10
[F] BUZZER	(0) ▶ (03) ▶ (1) ▶ T	10
[F] ENABLED	(1) ▶ (0) ▶ (1)→(8) ▶ (1) ▶ T	35
[F] PULSE BELL	(0) ▶ (03) ▶ (1) ▶ T	10
[F][A][P] KEYS	(0) ▶ (05) ▶ (3) ▶ (05)	26
[P] ENABLED	(1) ▶ (0) ▶ (1)→(8) ▶ (1) ▶ T	35
[P] SIL BELL	(0) ▶ (03) ▶ (1) ▶ T	10
[P] SILENT BUZ	(0) ▶ (03) ▶ (1) ▶ T	10
[P] STDY BELL	(0) ▶ (03) ▶ (1) ▶ T	10
1200 BAUD	(0) ▶ (09) ▶ (0) ▶ (2)	34
1ST NUMBER	(0) ▶ (05) ▶ (0) ▶ (0)	14
2 CALL TIMER	(0) ▶ (04) ▶ (5)	13
24 HR BELL (Add)	(1) ▶ (0) ▶ (1)→(8) ▶ (3) ▶ (0) ▶ WHICH ZONE ▶ (1) ▶ (06)	38
(Edit)	(1) ▶ (0) ▶ (1)→(8) ▶ (3) ▶ (1) ▶ WHICH ZONE ▶ (1) ▶ (06)	38
24 HR BELL/BUZZ (Add)	(1) ▶ (0) ▶ (1)→(8) ▶ (3) ▶ (0) ▶ WHICH ZONE ▶ (1) ▶ (07)	39
(Edit)	(1) ▶ (0) ▶ (1)→(8) ▶ (3) ▶ (1) ▶ WHICH ZONE ▶ (1) ▶ (07)	39
24 HR BUZZER (Add)	(1) ▶ (0) ▶ (1)→(8) ▶ (3) ▶ (0) ▶ WHICH ZONE ▶ (1) ▶ (08)	39
(Edit)	(1) ▶ (0) ▶ (1)→(8) ▶ (3) ▶ (1) ▶ WHICH ZONE ▶ (1) ▶ (08)	39
2400 BAUD	(0) ▶ (09) ▶ (0) ▶ (3)	34
2ND MASTER CLOSE	(0) ▶ (05) ▶ (3) ▶ (13)	27
2ND MASTER OPEN	(0) ▶ (05) ▶ (3) ▶ (14)	27
2ND NUMBER	(0) ▶ (05) ▶ (0) ▶ (1)	14
300 BAUD	(0) ▶ (09) ▶ (0) ▶ (0)	34
3RD NUMBER	(0) ▶ (05) ▶ (0) ▶ (2)	14

4204 MOD MAINT	(0) ▶ (05) ▶ (3) ▶ (11)	27
4204 OPTIONS	(0) ▶ (08) ▶ (1)	30
4216 CUSTOM	(0) ▶ (08) ▶ (3)	30
4216 OPTIONS	(0) ▶ (08) ▶ (2)	30
4400 MOD MAINT	(0) ▶ (05) ▶ (3) ▶ (12)	27
60 Hz LINE	(0) ▶ (03) ▶ (0) ▶ T	8
600 BAUD	(0) ▶ (09) ▶ (0) ▶ (1)	34

A	Quick Message Numbers	Page
ABORT REQ CODE	(1) ▶ (0) ▶ (1)→(8) ▶ (1) ▶ T	35
AC FAIL TX DELAY	(0) ▶ (05) ▶ (2) ▶ (2)	24
AC INHIBIT ARM	(0) ▶ (03) ▶ (0) ▶ T	8
AC TBL DISP	(0) ▶ (03) ▶ (0) ▶ T	8
ACCESS CODE	(0) ▶ (04) ▶ (4)	13
ADD NEW ZONE	(1) ▶ (0) ▶ (1)→(8) ▶ (3) ▶ (0)	37
ADD/EDIT PAR	(1) ▶ (0)	35
ALARM REPCODE (Add)	(1) ▶ (0) ▶ (1)→(8) ▶ (3) ▶ (0) ▶ WHICH ZONE ▶ (3) ▶ (0)	40
(Edit)	(1) ▶ (0) ▶ (1)→(8) ▶ (3) ▶ (1) ▶ WHICH ZONE ▶ (3) ▶ (0)	40
ALARM WHEN ARMED	(0) ▶ (01) ▶ (1) ▶ (1)	6
ALARM/RESTORE (Phone #1)	(0) ▶ (05) ▶ (0) ▶ (0) ▶ (2) ▶ T	21
(Phone #2)	(0) ▶ (05) ▶ (0) ▶ (1) ▶ (2) ▶ T	21
(Phone #3)	(0) ▶ (05) ▶ (0) ▶ (2) ▶ (2) ▶ T	21
ALARMS 1-16	(0) ▶ (08) ▶ (2) ▶ (1)→(8) ▶ (01)	30
ALARMS 17-32	(0) ▶ (08) ▶ (2) ▶ (1)→(8) ▶ (02)	30
ALARMS 33-48	(0) ▶ (08) ▶ (2) ▶ (1)→(8) ▶ (03)	30
ALARMS 49-64	(0) ▶ (08) ▶ (2) ▶ (1)→(8) ▶ (04)	30
ALARMS 65-80	(0) ▶ (08) ▶ (2) ▶ (1)→(8) ▶ (05)	30
ALARMS 81-96	(0) ▶ (08) ▶ (2) ▶ (1)→(8) ▶ (06)	30
ALARMS 97-112	(0) ▶ (08) ▶ (2) ▶ (1)→(8) ▶ (07)	30
ALARMS 113-128	(0) ▶ (08) ▶ (2) ▶ (1)→(8) ▶ (08)	30
ALARMS DISP	(0) ▶ (03) ▶ (0) ▶ T	8
ALL OTHERS (Phone #1)	(0) ▶ (05) ▶ (0) ▶ (0) ▶ (2) ▶ T	21
(Phone #2)	(0) ▶ (05) ▶ (0) ▶ (1) ▶ (2) ▶ T	21
(Phone #3)	(0) ▶ (05) ▶ (0) ▶ (2) ▶ (2) ▶ T	21
ASSIGN CODES	(0) ▶ (02) ▶ (0)-(8)	7
AUTOARM ENAB	(1) ▶ (0) ▶ (1)→(8) ▶ (1) ▶ T	35
AUTOARM SQUAWK	(0) ▶ (03) ▶ (0) ▶ T	9
AUTO VER FIRE (Add)	(1) ▶ (0) ▶ (1)→(8) ▶ (3) ▶ (0) ▶ WHICH ZONE ▶ (1) ▶ (11)	39
(Edit)	(1) ▶ (0) ▶ (1)→(8) ▶ (3) ▶ (1) ▶ WHICH ZONE ▶ (1) ▶ (11)	39
AUX ENTRY DELAY	(1) ▶ (0) ▶ (1)→(8) ▶ (2) ▶ (2)	36
AUX EXIT DELAY	(1) ▶ (0) ▶ (1)→(8) ▶ (2) ▶ (3)	36
AUXILIARY DELAY (Add)	(1) ▶ (0) ▶ (1)→(8) ▶ (3) ▶ (0) ▶ WHICH ZONE ▶ (1) ▶ (01)	38
(Edit)	(1) ▶ (0) ▶ (1)→(8) ▶ (3) ▶ (1) ▶ WHICH ZONE ▶ (1) ▶ (01)	38

B		Quick Message Numbers	Page
BAUD RATE	(0) ▶ (09) ▶ (0)		34
BELL AUDIBLE (Add)	(1) ▶ (0) ▶ (1)→(8) ▶ (3) ▶ (0) ▶ WHICH ZONE ▶ (2) ▶ T		40
(Edit)	(1) ▶ (0) ▶ (1)→(8) ▶ (3) ▶ (1) ▶ WHICH ZONE ▶ (2) ▶ T		40
BELL CUTOFF	(0) ▶ (03) ▶ (3) ▶ (2)		11
BELL PULSED (Add)	(1) ▶ (0) ▶ (1)→(8) ▶ (3) ▶ (0) ▶ WHICH ZONE ▶ (2) ▶ T		40
(Edit)	(1) ▶ (0) ▶ (1)→(8) ▶ (3) ▶ (1) ▶ WHICH ZONE ▶ (2) ▶ T		40
BELL SHUT DOWN	(0) ▶ (03) ▶ (0) ▶ T		9
BELL SQUAWK ON	(1) ▶ (0) ▶ (1)→(8) ▶ (1) ▶ T		36
BINARY PROGRAM	(4) ▶ (1)		45
BURG ONLY (SW Aux)	(0) ▶ (06) ▶ (02)		32
(Main Bell)	(0) ▶ (07) ▶ (02)		32
(Main PGM)	(0) ▶ (08) ▶ (0) ▶ (02)		32
(4204)	(0) ▶ (08) ▶ (1) ▶ (01)→(16) ▶ (1)→(4) ▶ (02)		32
(4216 custom)	(0) ▶ (08) ▶ (3) ▶ (01)→(16) ▶ (02)		32
BYPAS REQ CODE	(1) ▶ (0) ▶ (1)→(8) ▶ (1) ▶ T		35
BYPASS DISP	(0) ▶ (03) ▶ (0) ▶ T		9
BYPASS ENABLED (Add)	(1) ▶ (0) ▶ (1)→(8) ▶ (3) ▶ (0) ▶ WHICH ZONE ▶ (2) ▶ T		40
(Edit)	(1) ▶ (0) ▶ (1)→(8) ▶ (3) ▶ (1) ▶ WHICH ZONE ▶ (2) ▶ T		40
C		Quick Message Numbers	Page
CHANGE SYS MAS	(0) ▶ (03) ▶ (0) ▶ T		8
CHIME FOLLOWER (SW Aux)	(0) ▶ (06) ▶ (12)		32
(Main Bell)	(0) ▶ (07) ▶ (12)		32
(Main PGM)	(0) ▶ (08) ▶ (0) ▶ (12)		32
(4204)	(0) ▶ (08) ▶ (1) ▶ (01)→(16) ▶ (1)→(4) ▶ (12)		32
(4216 custom)	(0) ▶ (08) ▶ (3) ▶ (01)→(16) ▶ (12)		32
CHIME FUNCTION (Add)	(1) ▶ (0) ▶ (1)→(8) ▶ (3) ▶ (0) ▶ WHICH ZONE ▶ (2) ▶ T		40
(Edit)	(1) ▶ (0) ▶ (1)→(8) ▶ (3) ▶ (1) ▶ WHICH ZONE ▶ (2) ▶ T		40
CHIME PULSE	(0) ▶ (08) ▶ (4) ▶ (3)		31
CLOSINGS	(0) ▶ (05) ▶ (3) ▶ (06)		26
CODE ASSIGNMENT	(0) ▶ (02)		7
COMBUS POWER (SW Aux)	(0) ▶ (06) ▶ (19)		33
(Main Bell)	(0) ▶ (07) ▶ (19)		33
(Main PGM)	(0) ▶ (08) ▶ (0) ▶ (19)		33
(4204)	(0) ▶ (08) ▶ (1) ▶ (01)→(16) ▶ (1)→(4) ▶ (19)		33
(4216 custom)	(0) ▶ (08) ▶ (3) ▶ (01)→(16) ▶ (19)		33
COMMS ACTIVE (SW Aux)	(0) ▶ (06) ▶ (16)		33
(Main Bell)	(0) ▶ (07) ▶ (16)		33
(Main PGM)	(0) ▶ (08) ▶ (0) ▶ (16)		33
(4204)	(0) ▶ (08) ▶ (1) ▶ (01)→(16) ▶ (1)→(4) ▶ (16)		33
(4216 custom)	(0) ▶ (08) ▶ (3) ▶ (01)→(16) ▶ (16)		33
COMMS ENABLED	(0) ▶ (05) ▶ (1) ▶ T		22
COMMS FORMAT (Phone #1)	(0) ▶ (05) ▶ (0) ▶ (0) ▶ (1)		15
(Phone #2)	(0) ▶ (05) ▶ (0) ▶ (1) ▶ (1)		15
(Phone #3)	(0) ▶ (05) ▶ (0) ▶ (2) ▶ (1)		15
COMMS MISC	(0) ▶ (05) ▶ (2)		24
COMMS TOGGLES	(0) ▶ (05) ▶ (1)		22
COMMUNICATOR	(0) ▶ (05)		14
CONFIRM MODULE	(2) ▶ (2)		43
COPY PARTITION	(1) ▶ (2)		42
COURTESY PULSE (SW Aux)	(0) ▶ (06) ▶ (11)		32
(MAIN Bell)	(0) ▶ (07) ▶ (11)		32
(Main PGM)	(0) ▶ (08) ▶ (0) ▶ (11)		32
(4204)	(0) ▶ (08) ▶ (1) ▶ (01)→(16) ▶ (1)→(4) ▶ (11)		32
(4216 custom)	(0) ▶ (08) ▶ (3) ▶ (01)→(16) ▶ (11)		32
CREATE TAMPER ON DESIRED UNIT (Enroll)			
(4400)	(2) ▶ (0) ▶ (1)		43
(41XX)	(2) ▶ (0) ▶ (2)		43
(4216 custom)	(2) ▶ (0) ▶ (3)		43
(4204)	(2) ▶ (0) ▶ (4)		43
(Confirm)			
(4400)	(2) ▶ (2) ▶ (1)		43
(41XX)	(2) ▶ (2) ▶ (2)		43
(4216 custom)	(2) ▶ (2) ▶ (3)		43
(4204)	(2) ▶ (2) ▶ (4)		43
CUSTOM PGM ARRAY	(0) ▶ (08) ▶ (2) ▶ (1)→(9) ▶ (00)		30
CUSTOM ZONE ID	(0) ▶ (01) ▶ (0)		6
CUSTOMER ID CODE	(1) ▶ (0) ▶ (1)→(8) ▶ (0)		35
D		Quick Message Numbers	Page
DC INHIBIT ARM	(0) ▶ (03) ▶ (0) ▶ T		8
DEFAULT DIAL	(0) ▶ (05) ▶ (1) ▶ T		24
DELAY HOME AWAY (Add)	(1) ▶ (0) ▶ (1)→(8) ▶ (3) ▶ (0) ▶ WHICH ZONE ▶ (1) ▶ (05)		38
(Edit)	(1) ▶ (0) ▶ (1)→(8) ▶ (3) ▶ (1) ▶ WHICH ZONE ▶ (1) ▶ (05)		38
DELAYED FIRE (Add)	(1) ▶ (0) ▶ (1)→(8) ▶ (3) ▶ (0) ▶ WHICH ZONE ▶ (1) ▶ (10)		39
(Edit)	(1) ▶ (0) ▶ (1)→(8) ▶ (3) ▶ (1) ▶ WHICH ZONE ▶ (1) ▶ (10)		39
DELETE MODULE	(2) ▶ (1)		43
DELETE PARTITION	(1) ▶ (1)		42
DELETE ZONE	(1) ▶ (0) ▶ (1)→(8) ▶ (3) ▶ (2)		41
DIAGNOSTICS (Main Menu)	(4)		45
(Option)	(4) ▶ (0)		45
DIALER DIRECTION (Phone #1)	(0) ▶ (05) ▶ (0) ▶ (0) ▶ (2)		21
(Phone #2)	(0) ▶ (05) ▶ (0) ▶ (1) ▶ (2)		21
(Phone #3)	(0) ▶ (05) ▶ (0) ▶ (2) ▶ (2)		21
DISABLE LOCKOUT	(0) ▶ (00) ▶ (3) ▶ (2)		5
DISP EXIT TIME	(1) ▶ (0) ▶ (1)→(8) ▶ (1) ▶ T		35

DISPLAY CLOCK	(1) ▶ (0) ▶ (1)▶(8) ▶ (1) ▶ T	35
DLS CALLBACK	(0) ▶ (04) ▶ (0) ▶ T	12
DLS REPORT CODES	(0) ▶ (04) ▶ (7)	13
DLS SECTION	(0) ▶ (04)	12
DLS TOGGLES	(0) ▶ (04) ▶ (0)	12
DOUBLE CALL	(0) ▶ (04) ▶ (0) ▶ T	12
DTMF ATTEMPTS	(0) ▶ (05) ▶ (2) ▶ (0)	24
DTMF DIALING	(0) ▶ (05) ▶ (1) ▶ T	22

E	Quick Message Numbers	Page
EDIT ZONE	(1) ▶ (0) ▶ (1)▶(8) ▶ (3) ▶ (1)	37
ENABLE LOCKOUT	(0) ▶ (00) ▶ (3) ▶ (0)	5
ENROLL MODULE	(2) ▶ (0)	43
ENT HEX ADDRESS	(4) ▶ (1) ▶ T	45
ENTRY DELAY	(1) ▶ (0) ▶ (1)▶(8) ▶ (2) ▶ (0)	36
EUROPE DIAL	(0) ▶ (05) ▶ (1) ▶ T	24
EVENT BUFFER	(3)	44
EVENT MESSAGES	(0) ▶ (01) ▶ (1)	6
EXIT DELAY	(1) ▶ (0) ▶ (1)▶(8) ▶ (2) ▶ (1)	36

F	Quick Message Numbers	Page
FACTORY DEFAULT	(4) ▶ (3)	45
FAIL TO ARM	(0) ▶ (01) ▶ (1) ▶ (0)	6
FAILURE TO COMM		
(SW Aux)	(0) ▶ (06) ▶ (15)	33
(Main Bell)	(0) ▶ (07) ▶ (15)	33
(Main PGM)	(0) ▶ (08) ▶ (0) ▶ (15)	33
(4204)	(0) ▶ (08) ▶ (1) ▶ (01)▶(16) ▶ (1)▶(4) ▶ (15)	33
(4216 custom)	(0) ▶ (08) ▶ (3) ▶ (01)▶(16) ▶ (15)	33
FIRE AND BURGLAR		
(SW Aux)	(0) ▶ (06) ▶ (00)	32
(Main Bell)	(0) ▶ (07) ▶ (00)	32
(Main PGM)	(0) ▶ (08) ▶ (0) ▶ (00)	32
(4204)	(0) ▶ (08) ▶ (1) ▶ (01)▶(16) ▶ (1)▶(4) ▶ (00)	32
(4216 custom)	(0) ▶ (08) ▶ (3) ▶ (01)▶(16) ▶ (00)	32
FIRE ONLY		
(SW Aux)	(0) ▶ (06) ▶ (04)	32
(Main Bell)	(0) ▶ (07) ▶ (04)	32
(Main PGM)	(0) ▶ (08) ▶ (0) ▶ (04)	32
(4204)	(0) ▶ (08) ▶ (1) ▶ (01)▶(16) ▶ (1)▶(4) ▶ (04)	32
(4216 custom)	(0) ▶ (08) ▶ (3) ▶ (01)▶(16) ▶ (04)	32
FOLLOW 1-16	(0) ▶ (08) ▶ (2) ▶ (1)▶(8) ▶ (09)	30
FOLLOWS + ALARMS	(0) ▶ (03) ▶ (0) ▶ T	9
FORCE ARM		
(Add)	(1) ▶ (0) ▶ (1)▶(8) ▶ (3) ▶ (0) ▶ WHICH ZONE ▶ (2) ▶ T	40
(Edit)	(1) ▶ (0) ▶ (1)▶(8) ▶ (3) ▶ (1) ▶ WHICH ZONE ▶ (2) ▶ T	40
FORCED ANSWER		
(Add)	(1) ▶ (0) ▶ (1)▶(8) ▶ (3) ▶ (0) ▶ WHICH ZONE ▶ (1) ▶ (15)	39
(Edit)	(1) ▶ (0) ▶ (1)▶(8) ▶ (3) ▶ (1) ▶ WHICH ZONE ▶ (1) ▶ (15)	39

FORMATS		
(Phone #1)	(0) ▶ (05) ▶ (0) ▶ (0) ▶ (1) ▶ (00)▶(17)	15
(Phone #2)	(0) ▶ (05) ▶ (0) ▶ (1) ▶ (1) ▶ (00)▶(17)	15
(Phone #3)	(0) ▶ (05) ▶ (0) ▶ (2) ▶ (1) ▶ (00)▶(17)	15
FROM WHICH PARTITION ?		
	(1) ▶ (2) ▶ (1)▶(8)	42
FTC AUD BELL	(0) ▶ (05) ▶ (1) ▶ T	23

G	Quick Message Numbers	Page
GROUND START		
(SW Aux)	(0) ▶ (06) ▶ (17)	33
(Main Bell)	(0) ▶ (07) ▶ (17)	33
(Main PGM)	(0) ▶ (08) ▶ (0) ▶ (17)	33
(4204)	(0) ▶ (08) ▶ (1) ▶ (01)▶(16) ▶ (1)▶(4) ▶ (17)	33
(4216 custom)	(0) ▶ (08) ▶ (3) ▶ (01)▶(16) ▶ (17)	33
(PGM Pulse Time)	(0) ▶ (08) ▶ (4) ▶ (2)	31

H	Quick Message Numbers	Page
HANDSHAKE	(0) ▶ (09) ▶ (1)	34
HANDSHAKE OFF	(0) ▶ (09) ▶ (1) ▶ T	34

I	Quick Message Numbers	Page
INS LOCKOUT OPTS	(0) ▶ (00) ▶ (3)	5
INSTALLER OPTS	(0) ▶ (00)	5
INSTANT		
(Add)	(1) ▶ (0) ▶ (1)▶(8) ▶ (3) ▶ (0) ▶ WHICH ZONE ▶ (1) ▶ (02)	38
(Edit)	(1) ▶ (0) ▶ (1)▶(8) ▶ (3) ▶ (1) ▶ WHICH ZONE ▶ (1) ▶ (02)	38
INT HOME AWAY		
(Add)	(1) ▶ (0) ▶ (1)▶(8) ▶ (3) ▶ (0) ▶ WHICH ZONE ▶ (1) ▶ (04)	38
(Edit)	(1) ▶ (0) ▶ (1)▶(8) ▶ (3) ▶ (1) ▶ WHICH ZONE ▶ (1) ▶ (04)	38
INTERIOR		
(Add)	(1) ▶ (0) ▶ (1)▶(8) ▶ (3) ▶ (0) ▶ WHICH ZONE ▶ (1) ▶ (03)	38
(Edit)	(1) ▶ (0) ▶ (1)▶(8) ▶ (3) ▶ (1) ▶ WHICH ZONE ▶ (1) ▶ (03)	38
INV BURGLAR ONLY		
(SW Aux)	(0) ▶ (06) ▶ (03)	32
(Main Bell)	(0) ▶ (07) ▶ (03)	32
(Main PGM)	(0) ▶ (08) ▶ (0) ▶ (03)	32
(4204)	(0) ▶ (08) ▶ (1) ▶ (01)▶(16) ▶ (1)▶(4) ▶ (03)	32
(4216 custom)	(0) ▶ (08) ▶ (3) ▶ (01)▶(16) ▶ (03)	32
INV FIRE ONLY		
(SW Aux)	(0) ▶ (06) ▶ (05)	32
(Main Bell)	(0) ▶ (07) ▶ (05)	32
(Main PGM)	(0) ▶ (08) ▶ (0) ▶ (05)	32
(4204)	(0) ▶ (08) ▶ (1) ▶ (01)▶(16) ▶ (1)▶(4) ▶ (05)	32
(4216 custom)	(0) ▶ (08) ▶ (3) ▶ (01)▶(16) ▶ (05)	32
INV FIRE/BURGLAR		
(SW Aux)	(0) ▶ (06) ▶ (01)	32
(Main Bell)	(0) ▶ (07) ▶ (01)	32
(Main PGM)	(0) ▶ (08) ▶ (0) ▶ (01)	32
(4204)	(0) ▶ (08) ▶ (1) ▶ (01)▶(16) ▶ (1)▶(4) ▶ (01)	32
(4216 custom)	(0) ▶ (08) ▶ (3) ▶ (01)▶(16) ▶ (01)	32

K	Quick Message Numbers	Page
KEYPAD TOG OPT	(0) ▶ (03) ▶ (1)	10
KISSOFF OUTPUT		
(SW Aux)	(0) ▶ (06) ▶ (18)	33
(Main Bell)	(0) ▶ (07) ▶ (18)	33
(Main PGM)	(0) ▶ (08) ▶ (0) ▶ (18)	33
(4204)	(0) ▶ (08) ▶ (1) ▶ (01)▶(16) ▶ (1)▶(4) ▶ (18)	33
(4216 custom)	(0) ▶ (08) ▶ (3) ▶ (01)▶(16) ▶ (18)	33
KISSOFF PULSE	(0) ▶ (08) ▶ (4) ▶ (1)	31
KYPD LOCKOUT OPT	(0) ▶ (03) ▶ (2)	11
KYPD LOCKOUT ?	(1) ▶ (0) ▶ (1)▶(8) ▶ (1) ▶ T	36

L	Quick Message Numbers	Page
LATCHED STROBE		
(SW Aux)	(0) ▶ (06) ▶ (09)	32
(Main Bell)	(0) ▶ (07) ▶ (09)	32
(Main PGM)	(0) ▶ (08) ▶ (0) ▶ (09)	32
(4204)	(0) ▶ (08) ▶ (1) ▶ (01)▶(16) ▶ (1)▶(4) ▶ (09)	32
(4216 custom)	(0) ▶ (08) ▶ (3) ▶ (01)▶(16) ▶ (09)	32
LATCHING 24 HR		
(Add)	(1) ▶ (0) ▶ (1)▶(8) ▶ (3) ▶ (0) ▶ WHICH ZONE ▶ (1) ▶ (14)	39
(Edit)	(1) ▶ (0) ▶ (1)▶(8) ▶ (3) ▶ (1) ▶ WHICH ZONE ▶ (1) ▶ (14)	39
LCD MESSAGES	(0) ▶ (01)	6
LCD4500 KEYPADS		
(Alarm)	(0) ▶ (05) ▶ (3) ▶ (03) ▶ (0)	25
(Restore)	(0) ▶ (05) ▶ (3) ▶ (04) ▶ (0)	26
(Enroll)	(2) ▶ (0) ▶ (0)	43
>Delete)	(2) ▶ (1) ▶ (0)	43
(Confirm)	(2) ▶ (2) ▶ (0)	43
LEAD IN REPCODE	(0) ▶ (04) ▶ (7) ▶ (0)	13
LEAD OUT REPCODE	(0) ▶ (04) ▶ (7) ▶ (1)	13
LOCKOUT DURATION	(0) ▶ (03) ▶ (2) ▶ (1)	11
LOCKOUT REP CODE	(0) ▶ (03) ▶ (2) ▶ (2)	11

M	Quick Message Numbers	Page
MAIN BELL OUTPUT	(0) ▶ (07)	29
MAIN ITEMS	(0) ▶ (05) ▶ (0)	14
MAIN PGM OUT	(0) ▶ (08) ▶ (0)	30
MAINTAINED ARM		
(Add)	(1) ▶ (0) ▶ (1)▶(8) ▶ (3) ▶ (0) ▶ WHICH ZONE ▶ (1) ▶ (13)	39
(Edit)	(1) ▶ (0) ▶ (1)▶(8) ▶ (3) ▶ (1) ▶ WHICH ZONE ▶ (1) ▶ (13)	39
MEMORIZE VBAT	(4) ▶ (2)	45
MISC CLOSINGS	(0) ▶ (05) ▶ (3) ▶ (07)	26
MISC OPENINGS	(0) ▶ (05) ▶ (3) ▶ (09)	26
MOD TAMP ALARM	(0) ▶ (05) ▶ (3) ▶ (03)	25
MOD TAMP RESTORE	(0) ▶ (05) ▶ (3) ▶ (04)	26
MODULE HARDWARE	(2)	3

MODULE NUMBER	Page	
(LCD4500)	(2) ▶ (1) ▶ (0) ▶ (01)▶(16)	43
(41XX)	(2) ▶ (1) ▶ (2) ▶ (01)▶(16)	43
(4216)	(2) ▶ (1) ▶ (3) ▶ (1)▶(9)	43
(4204)	(2) ▶ (1) ▶ (4) ▶ (01)▶16)	43

MOMENTARY ARM	Page	
(Add)	(1) ▶ (0) ▶ (1)▶(8) ▶ (3) ▶ (0) ▶ WHICH ZONE ▶ (1) ▶ (12)	39
(Edit)	(1) ▶ (0) ▶ (1)▶(8) ▶ (3) ▶ (1) ▶ WHICH ZONE ▶ (1) ▶ (12)	39

O	Quick Message Numbers	Page
OPEN/CLOSE		
(Phone #1)	(0) ▶ (05) ▶ (0) ▶ (0) ▶ (2) ▶ T	21
(Phone #2)	(0) ▶ (05) ▶ (0) ▶ (1) ▶ (2) ▶ T	21
(Phone #3)	(0) ▶ (05) ▶ (0) ▶ (2) ▶ (2) ▶ T	21
OPENINGS	(0) ▶ (05) ▶ (3) ▶ (08)	26

P	Quick Message Numbers	Page
PANEL ID CODE	(0) ▶ (04) ▶ (3)	13
PAR 1 CODES	(0) ▶ (02) ▶ (1)	7
PAR 2 CODES	(0) ▶ (02) ▶ (2)	7
PAR 3 CODES	(0) ▶ (02) ▶ (3)	7
PAR 4 CODES	(0) ▶ (02) ▶ (4)	7
PAR 5 CODES	(0) ▶ (02) ▶ (5)	7
PAR 6 CODES	(0) ▶ (02) ▶ (6)	7
PAR 7 CODES	(0) ▶ (02) ▶ (7)	7
PAR 8 CODES	(0) ▶ (02) ▶ (8)	7
PAR NAME LABEL	(1) ▶ (0) ▶ (1)▶(8) ▶ (4)	41
PAR TOGGLES	(1) ▶ (0) ▶ (1)▶(8) ▶ (1)	35
PARTITION AREA	(1)	3
PARTITION STATUS		
(SW Aux)	(0) ▶ (06) ▶ (08)	32
(Main Bell)	(0) ▶ (07) ▶ (08)	32
(Main PGM)	(0) ▶ (08) ▶ (0) ▶ (08)	32
(4204)	(0) ▶ (08) ▶ (1) ▶ (01)▶(16) ▶ (1)▶(4) ▶ (08)	32
(4216 custom)	(0) ▶ (08) ▶ (3) ▶ (01)▶(16) ▶ (08)	32
PARTITION TIMES	(1) ▶ (0) ▶ (1)▶(8) ▶ (2)	36
PARTITION...X Y/N		
(SW Aux)	(0) ▶ U(06) ▶ (00)-(08)	28
(SW Aux)	(0) ▶ (06) ▶ (09)-(12), (14)	28
(Main Bell)	(0) ▶ (07) ▶ (00)-(08)	29
(Main Bell)	(0) ▶ (07) ▶ (09)-(12), (14)	29
(Main PGM)	(0) ▶ (08) ▶ (0) ▶ (00)-(08)	30
(Main PGM)	(0) ▶ (08) ▶ (0) ▶ (09)-(12), (14)	30
(4204)	(0) ▶ (08) ▶ (1) ▶ (01)▶(16) ▶ (1)▶(4) ▶ (00)-(08)	30
(4204)	(0) ▶ (08) ▶ (1) ▶ (01)▶(16) ▶ (1)▶(4) ▶ (09)-(12), (14)	30
(4216 custom)	(0) ▶ (08) ▶ (3) ▶ (01)▶(16) ▶ (00)-(08)	30
(4216 custom)	(0) ▶ (08) ▶ (3) ▶ (01)▶(16) ▶ (09)-(12), (14)	30
PC ID	(0) ▶ (05) ▶ (1) ▶ T	22
PC ID RESTORES	(0) ▶ (05) ▶ (1) ▶ T	23
PC ON AUTO ARM	(0) ▶ (05) ▶ (1) ▶ T	23

T	Quick Message Numbers	Page	W	Quick Message Numbers	Page
TEST CODE TX	(0) ▶ (05) ▶ (2) ▶ (4)	25	WHICH 4204		
TLM AND ALARM			(Communicator)	(0) ▶ (05) ▶ (3) ▶ (11) ▶ (01) ▶ (16)	27
(SW Aux)	(0) ▶ (06) ▶ (14)	33	(PGM out)	(0) ▶ (08) ▶ (1) ▶ (01) ▶ (16)	30
(Main Bell)	(0) ▶ (07) ▶ (14)	33	WHICH 4216	(0) ▶ (08) ▶ (2) ▶ (1) ▶ (9)	30
(Main PGM)	(0) ▶ (08) ▶ (0) ▶ (14)	33	WHICH OUTPUT		
(4204)	(0) ▶ (08) ▶ (1) ▶ (01) ▶ (16) ▶ (1) ▶ (4) ▶ (14)	33	(4204)	(0) ▶ (08) ▶ (1) ▶ (01) ▶ (16) ▶ (1) ▶ (4)	30
(4216 custom)	(0) ▶ (08) ▶ (3) ▶ (01) ▶ (16) ▶ (14)	33	(4216 custom)	(0) ▶ (08) ▶ (3) ▶ (01) ▶ (16)	30
TLM + ALARM AUD	(0) ▶ (05) ▶ (1) ▶ T	23	WHICH PARTITION		
TLM AUD BELL	(0) ▶ (05) ▶ (1) ▶ T	23	(Add)	(1) ▶ (0) ▶ (1) ▶ (8)	35
TLM ENABLED	(0) ▶ (05) ▶ (1) ▶ T	23	(Delete)	(1) ▶ (1) ▶ (1) ▶ (8)	35
TLM ONLY			WHICH ZONE ?		
(SW Aux)	(0) ▶ (06) ▶ (13)	33	(Add)	(1) ▶ (0) ▶ (1) ▶ (8) ▶ (3) ▶ (0)	37
(Main Bell)	(0) ▶ (07) ▶ (13)	33	(Edit)	(1) ▶ (0) ▶ (1) ▶ (8) ▶ (3) ▶ (1)	37
(Main PGM)	(0) ▶ (08) ▶ (0) ▶ (13)	33	(Delete)	(1) ▶ (0) ▶ (1) ▶ (8) ▶ (3) ▶ (2) ▶ (001) ▶ (128)	41
(4204)	(0) ▶ (08) ▶ (1) ▶ (01) ▶ (16) ▶ (1) ▶ (4) ▶ (13)	33	X	Quick Message Numbers	Page
(4216 custom)	(0) ▶ (08) ▶ (3) ▶ (01) ▶ (16) ▶ (13)	33	XTAL TIMEBASE	(0) ▶ (03) ▶ (0) ▶ T	8
TO WHICH PARTITION ?			Z	Quick Message Numbers	Page
	(1) ▶ (2) ▶ (1) ▶ (8) ▶ (1) ▶ (8)	42	ZONE ALARM		
TOTAL BAD CODES	(0) ▶ (03) ▶ (2) ▶ (0)	11	(Rep Code)	(0) ▶ (05) ▶ (3) ▶ (00)	25
TROUBLE OUTPUT			(SW Aux)	(0) ▶ (06) ▶ (21)	33
(SW Aux)	(0) ▶ (06) ▶ (10)	32	(Main Bell)	(0) ▶ (07) ▶ (21)	33
(Main Bell)	(0) ▶ (07) ▶ (10)	32	(Main PGM)	(0) ▶ (08) ▶ (0) ▶ (21)	33
(Main PGM)	(0) ▶ (08) ▶ (0) ▶ (10)	32	(4204)	(0) ▶ (08) ▶ (1) ▶ (01) ▶ (16) ▶ (1) ▶ (4) ▶ (21)	33
(4204)	(0) ▶ (08) ▶ (1) ▶ (01) ▶ (16) ▶ (1) ▶ (4) ▶ (10)	32	(4216 custom)	(0) ▶ (08) ▶ (3) ▶ (01) ▶ (16) ▶ (21)	33
(4216 custom)	(0) ▶ (08) ▶ (3) ▶ (01) ▶ (16) ▶ (10)	32	ZONE ASSIGNMENT	(1) ▶ (0) ▶ (1) ▶ (8) ▶ (3)	37
TX DELAY ?			ZONE FOLLOW	(1) ▶ (0) ▶ (1) ▶ (8) ▶ (22)	33
(Add)	(1) ▶ (0) ▶ (1) ▶ (8) ▶ (3) ▶ (0) ▶ WHICH ZONE ▶ (2) ▶ (T)	40	ZONE LABEL		
(Edit)	(1) ▶ (0) ▶ (1) ▶ (8) ▶ (3) ▶ (1) ▶ WHICH ZONE ▶ (2) ▶ (T)	40	(Add)	(1) ▶ (0) ▶ (1) ▶ (8) ▶ (3) ▶ (0) ▶ WHICH ZONE ▶ (0)	37
			(Edit)	(1) ▶ (0) ▶ (1) ▶ (8) ▶ (3) ▶ (1) ▶ WHICH ZONE ▶ (0)	37
U	Quick Message Numbers	Page	ZONE OPTIONS		
USER CALL UP	(0) ▶ (04) ▶ (0) ▶ T	12	(Add)	(1) ▶ (0) ▶ (1) ▶ (8) ▶ (3) ▶ (0) ▶ WHICH ZONE ▶ (2)	40
USER ENABS DLS	(0) ▶ (04) ▶ (0) ▶ T	12	(Edit)	(1) ▶ (0) ▶ (1) ▶ (8) ▶ (3) ▶ (1) ▶ WHICH ZONE ▶ (2)	40
USER FN ANY CD	(1) ▶ (0) ▶ (1) ▶ (8) ▶ (1) ▶ T	36	ZONE RESPONSE	(0) ▶ (03) ▶ (3) ▶ (1)	11
UTIL REQ CODE	(1) ▶ (0) ▶ (1) ▶ (8) ▶ (1) ▶ T	36	ZONE RESTORE	(0) ▶ (05) ▶ (3) ▶ (02)	25
UTILITY OUTPUT			ZONE TROUBLE	(0) ▶ (05) ▶ (3) ▶ (01)	25
(SW Aux)	(0) ▶ (06) ▶ (06)	32	ZONE TX DELAY	(0) ▶ (05) ▶ (2) ▶ (3)	24
(Main Bell)	(0) ▶ (07) ▶ (06)	32	ZONE TYPE		
(Main PGM)	(0) ▶ (08) ▶ (0) ▶ (06)	32	(Add)	(1) ▶ (0) ▶ (1) ▶ (8) ▶ (3) ▶ (0) ▶ WHICH ZONE ▶ (1)	38
(4204)	(0) ▶ (08) ▶ (1) ▶ (01) ▶ (16) ▶ (1) ▶ (4) ▶ (06)	32	(Edit)	(1) ▶ (0) ▶ (1) ▶ (8) ▶ (3) ▶ (1) ▶ WHICH ZONE ▶ (1)	38
(4216 custom)	(0) ▶ (08) ▶ (3) ▶ (01) ▶ (16) ▶ (06)	32	ZONES EOL	(0) ▶ (03) ▶ (0) ▶ T	8
UTILITY/SENSOR	(0) ▶ (08) ▶ (4) ▶ (0)	31	ZONLAB 1ST WORD	(1) ▶ (0) ▶ (1) ▶ (8) ▶ (3) ▶ (0) ▶ WHICH ZONE ▶ (0) ▶ ZONE LABEL XXX CURRENT LABEL ▶ (0)	37
V	Quick Message Numbers	Page	ZONLAB 2ND WORD	(1) ▶ (0) ▶ (1) ▶ (8) ▶ (3) ▶ (0) ▶ WHICH ZONE ▶ (0) ▶ ZONE LABEL XXX CURRENT LABEL ▶ (1)	37
VIEW PARTNS	(0) ▶ (03) ▶ (0) ▶ T	9			

Feb 12, 1993
Software Version 1.3

PROGRAMMING MANUAL

This Book Contains:

- “How to Program the PC4000” section
- Detailed Information regarding each Program Section
- Appendix A - Zone Label Library
- Appendix B - Diagnostics Chart
- Appendix C - Calculating Line Loss
- Appendix D - Event Buffer Description
- Appendix E - On Site Printer Setup
- Appendix F - On Site Downloading Setup
- Appendix G - Troubleshooting Chart



PC4000
